

P-13724

S4178

38530

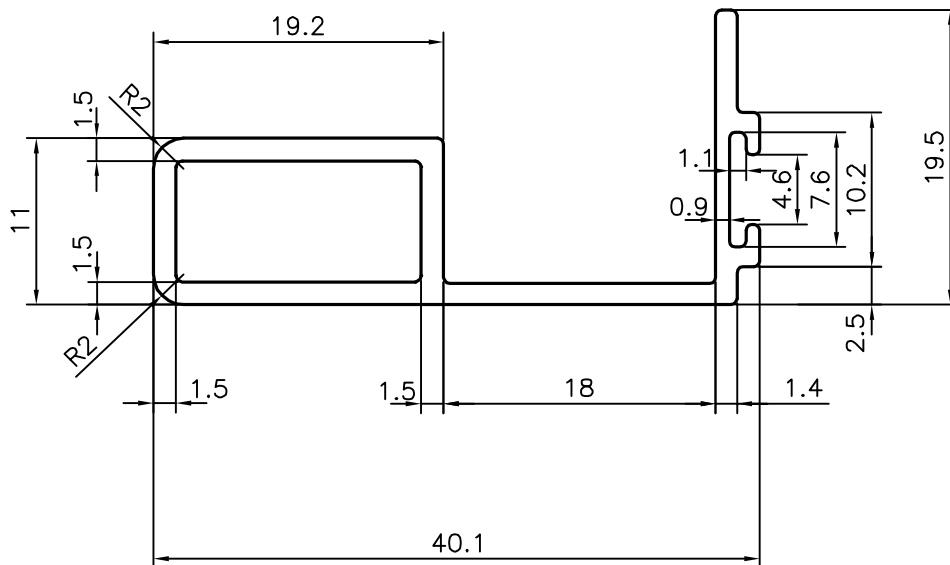
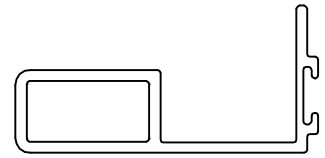

## TOLERANCES ON OVERALL WIDTHS &amp; WIDTHS ACROSS FLATS OF BARS, &amp; REGULAR SECTIONS

|                     |                      |                      |                       |
|---------------------|----------------------|----------------------|-----------------------|
| UPTO 6.40mm - ±0.20 | UPTO 32.0mm - ±0.38  | UPTO 120.0mm - ±0.85 | UPTO 320.00mm - ±1.70 |
| UPTO 10.0mm - ±0.23 | UPTO 50.0mm - ±0.46  | UPTO 160.0mm - ±1.02 |                       |
| UPTO 12.0mm - ±0.25 | UPTO 60.0mm - ±0.53  | UPTO 200.0mm - ±1.14 |                       |
| UPTO 16.0mm - ±0.28 | UPTO 80.0mm - ±0.69  | UPTO 250.0mm - ±1.40 |                       |
| UPTO 25.0mm - ±0.30 | UPTO 100.0mm - ±0.75 | UPTO 300.0mm - ±1.65 |                       |



SYMBOL OF QUALITY  
AN ISO 9001 COMPANY

**JINDAL ALUMINIUM LTD.**  
BANGALORE-560073 (INDIA)

|          | NAME        | DATE       |
|----------|-------------|------------|
| DRAWN    | J.P.KAUSHIK | 12-07-2014 |
| CHECKED  |             |            |
| APPROVED | S.S.GARG    | 21-07-2014 |

1. ALL DIMENSIONS ARE IN mm.
2. ROUND OFF ALL SHARP CORNERS WITH 0.40 mm.
3. TOLERANCES WILL BE AS PER IS:6477-1983, UNLESS OTHERWISE SPECIFIED

|                      |         |
|----------------------|---------|
| SCALE                | 2:1     |
| AREA mm <sup>2</sup> | 135.252 |
| PERIMETER mm.        | 143.593 |
| WEIGHT kg/m          | 0.365   |

|                     |                                       |
|---------------------|---------------------------------------|
| PARTY'S NAME        | RANJAN KHOSLA & SONS PVT. LTD., DELHI |
| PARTY'S DRAWING No. | AS PER SAMPLE & REQUIREMENT           |
| ALLOY & TEMPER      | 6063 T6                               |
| DESCRIPTION         | ARCHITECTURAL SECTION                 |

| DRAWING No. | SECTION No. |
|-------------|-------------|
| P-13724     | -           |
| S4178       | S4178       |
| 38530       | 38530       |