

P-16706

38539

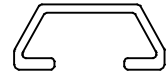

SCALE 1:1

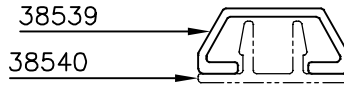
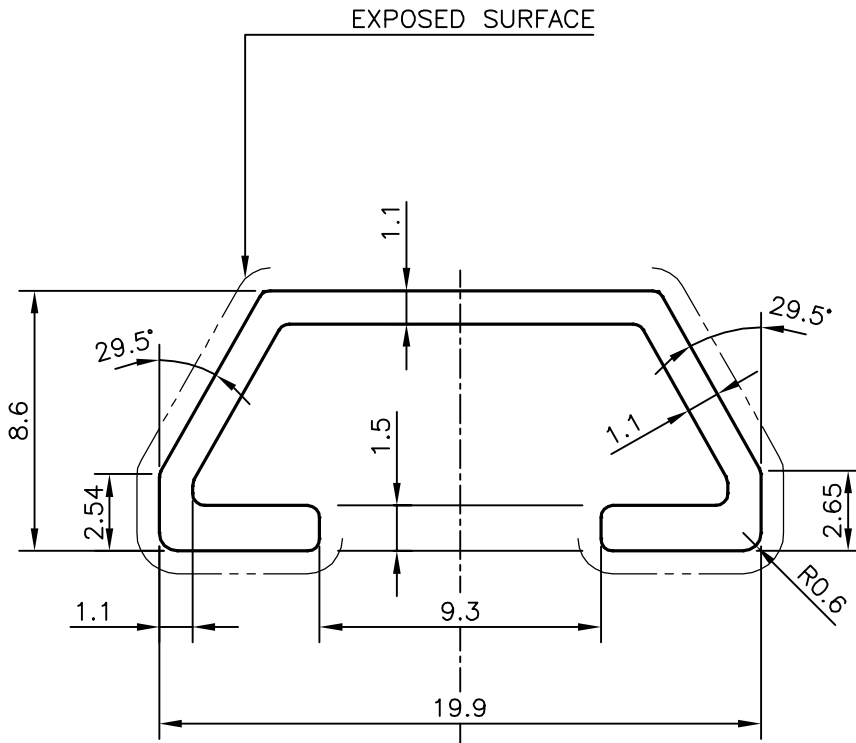

TOLERANCE CHART CD = CIRCUMSCRIBING CIRCLE

DIMENSION	CD<100	100<CD<200	200<CD<300	300<CD<500
UPTO 10mm	±0.25	±0.30	±0.35	±0.40
10.0 -25.0	±0.30	±0.40	±0.50	±0.60
25.0 -50.0	±0.50	±0.60	±0.80	±0.90
50.0 -100	±0.70	±0.90	±1.10	±1.30
100 - 150	-	±1.10	±1.30	±1.50
150 - 200	-	±1.3	±1.50	±1.80
200 - 300	-	-	±1.70	±2.10
300 - 450	-	-	-	±2.80



SYMBOL OF QUALITY
AN ISO 9001 COMPANY

JINDAL ALUMINIUM LTD.
BANGALORE-560073 (INDIA)

	NAME	DATE
DRAWN	KIRAN	04-01-2017
CHECKED		
APPROVED	B.NATARAJ	06-01-2017

1. ALL DIMENSIONS ARE IN mm.
2. ROUND OFF ALL SHARP CORNERS WITH 0.40 mm.
3. TOLERANCES WILL BE AS PER BS:EN-755-9, UNLESS OTHERWISE SPECIFIED

SCALE	4:1
AREA mm ²	45.632
PERIMETER mm.	77.723
WEIGHT kg/m	0.123

PARTY'S NAME	AMBITO SRL, PERU	DRAWING No.	SECTION No.
PARTY'S DRAWING No.	F-01	P-16706	
ALLOY & TEMPER	6063-T6	38539	38539
DESCRIPTION	MISC. SECTION		