

P-14548

S4440

38577

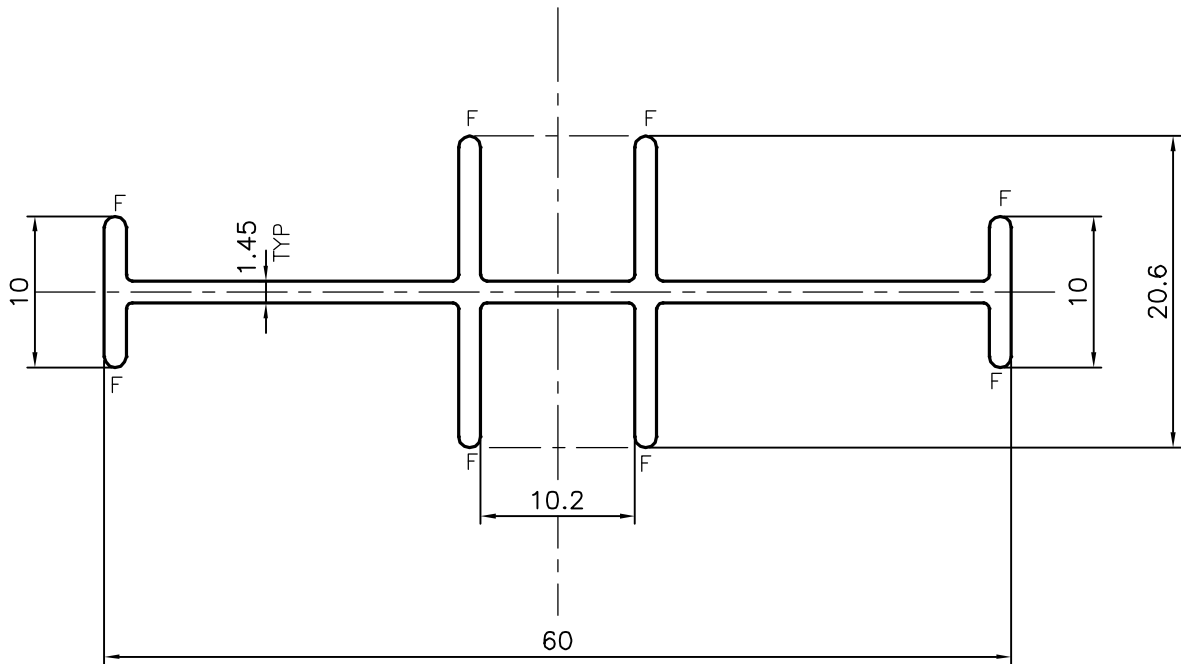
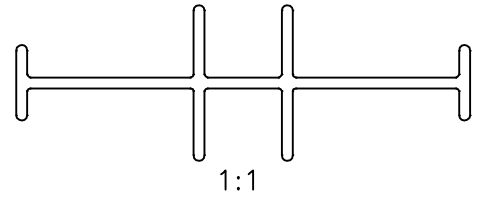

F = FULL RADIUS (8 PLACES)



SYMBOL OF QUALITY
AN ISO 9001 COMPANY

JINDAL ALUMINIUM LTD.
BANGALORE-560073 (INDIA)

	NAME	DATE
DRAWN	J.P.KAUSHIK	10-04-2015
CHECKED		
APPROVED	S.S.GARG	22-04-2015
SCALE		2:1
AREA mm ²		165.937
PERIMETER mm.		226.661
WEIGHT kg/m		0.448
DRAWING No.	SECTION No.	
P-14548	-	
S4440	S4440	
38577	38577	

1. ALL DIMENSIONS ARE IN mm.
2. ROUND OFF ALL SHARP CORNERS WITH 0.40 mm.
3. TOLERANCES WILL BE AS PER IS:3965-1981 UNLESS OTHERWISE SPECIFIED

PARTY'S NAME	AGUERRI INDUSTRIES PVT. LTD., CHENNAI
PARTY'S DRAWING No.	00684
ALLOY & TEMPER	6063 T5
DESCRIPTION	MISC. SECTION