

P-15539

X1964

38627

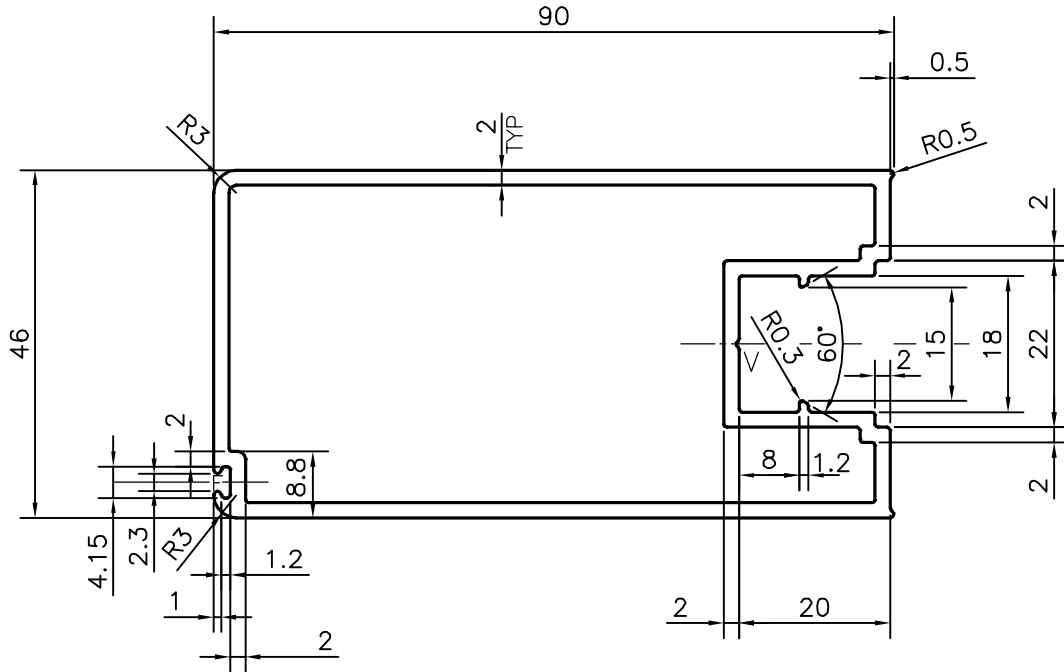
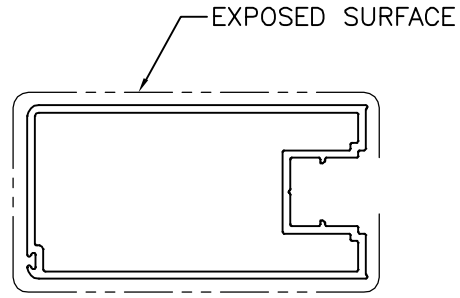

V = V GROOVE 0.4x90°
 F = FULL RADIUS (2 PLACES)



SYMBOL OF QUALITY
 AN ISO 9001 COMPANY

JINDAL ALUMINIUM LTD.
 BANGALORE-560073 (INDIA)

	NAME	DATE
DRAWN	J.P.KAUSHIK	25-01-2016
CHECKED		
APPROVED	S.S.GARG	01-02-2016
SCALE		1:1
AREA mm ²		613.723
PERIMETER mm.		319.104
WEIGHT kg/m		1.657
DRAWING No.	SECTION No.	
P-15539	-	
X1964	X1964	
38627	38627	

1. ALL DIMENSIONS ARE IN mm.
2. ROUND OFF ALL SHARP CORNERS WITH 0.40 mm.
3. TOLERANCES WILL BE AS PER,IS:6477-1983 UNLESS OTHERWISE SPECIFIED

PARTY'S NAME	HYTEK INTERIOR PRODUCTS., BANGALORE
PARTY'S DRAWING No.	AS PER AutoCAD DRAWING
ALLOY & TEMPER	HE9 WP
DESCRIPTION	MISC. SECTION