

P-15544

X1969

38631

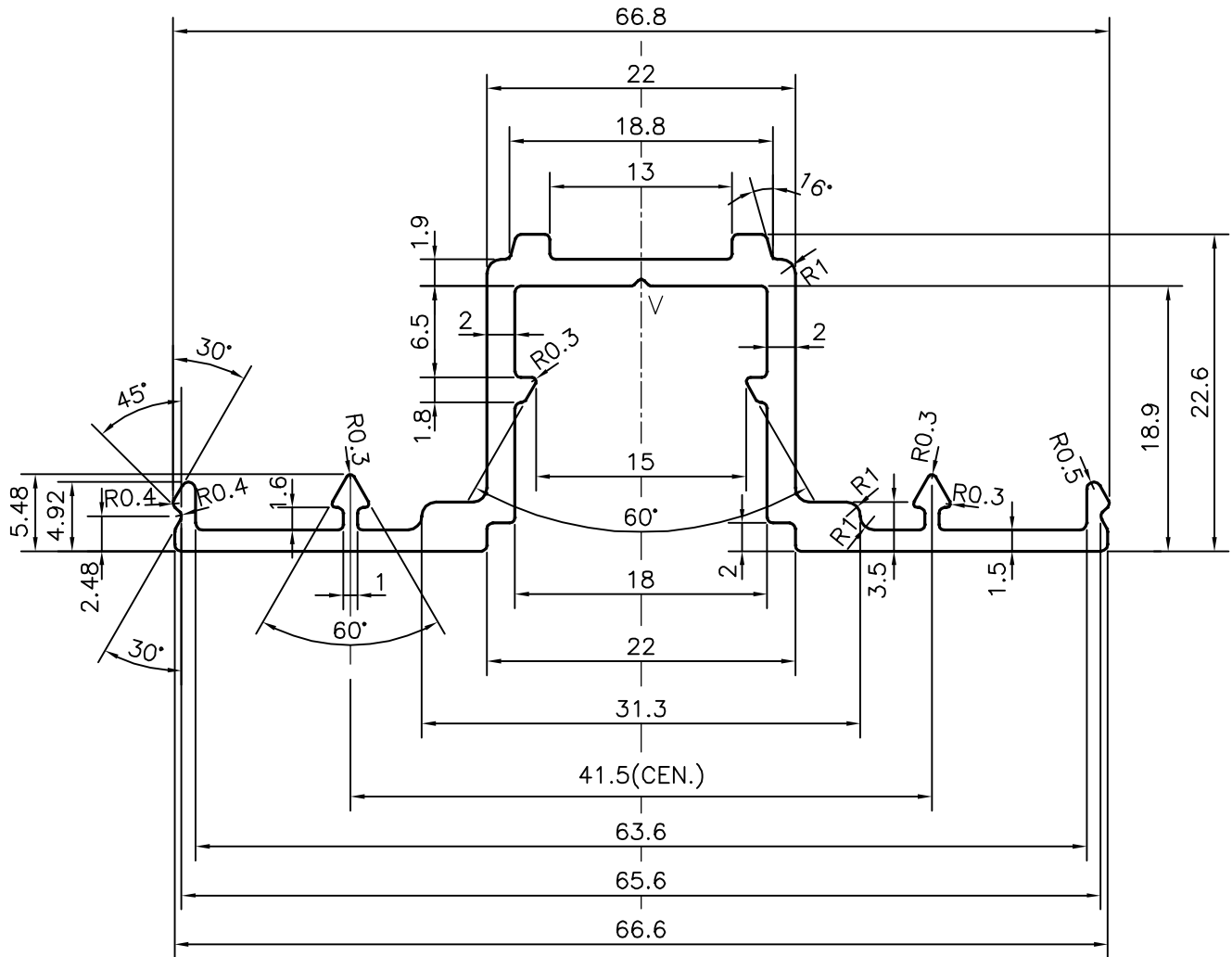
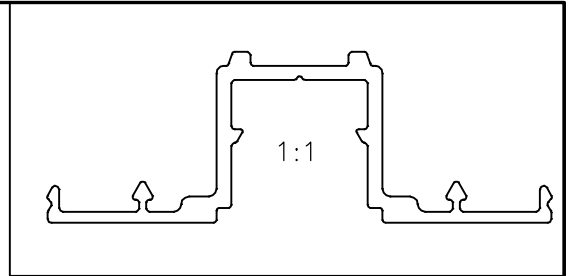
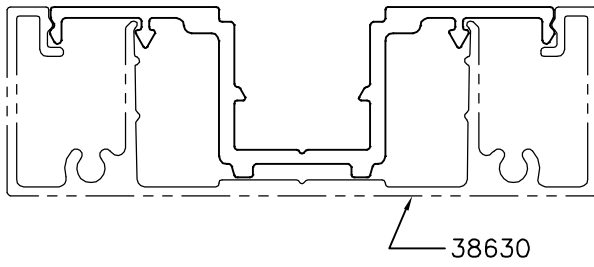

V= V GROOVE 0.5x90°



SYMBOL OF QUALITY
AN ISO 9001 COMPANY

JINDAL ALUMINIUM LTD.
BANGALORE-560073 (INDIA)

	NAME	DATE
DRAWN	J.P.KAUSHIK	25-01-2016
CHECKED		
APPROVED	S.S.GARG	01-02-2016
SCALE		2:1
AREA mm ²		228.136
PERIMETER mm.		246.314
WEIGHT kg/m		0.616
DRAWING No.	SECTION No.	
P-15544	-	
X1969	X1969	
38631	38631	

1. ALL DIMENSIONS ARE IN mm.
2. ROUND OFF ALL SHARP CORNERS WITH 0.40 mm.
3. TOLERANCES WILL BE AS PER,IS:3965-1981 UNLESS OTHERWISE SPECIFIED

PARTY'S NAME	HYTEK INTERIOR PRODUCTS., BANGALORE
PARTY'S DRAWING No.	AS PER AutoCAD DRAWING
ALLOY & TEMPER	HE9 WP
DESCRIPTION	MISC. SECTION