

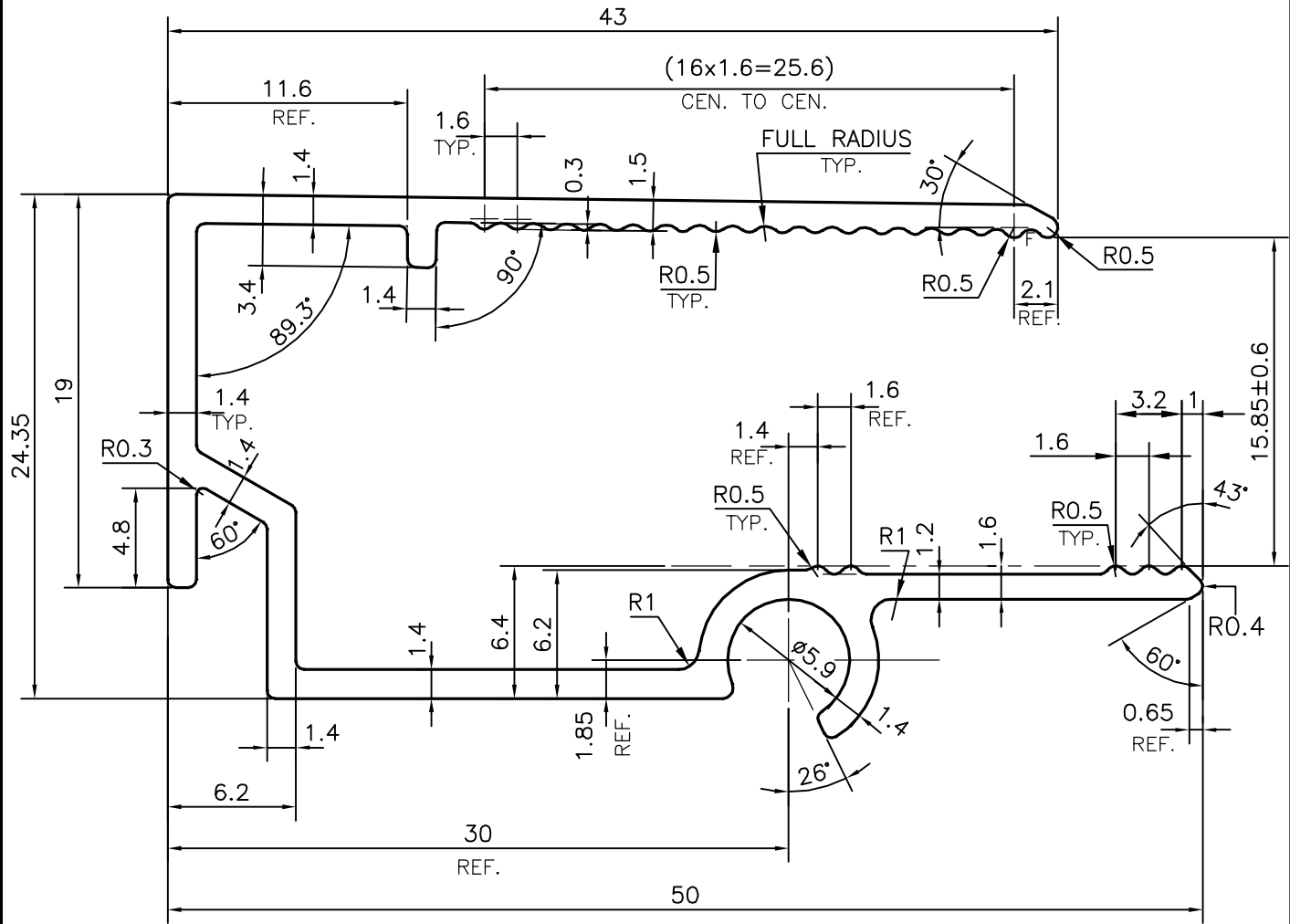

P-15716
S4892
38633

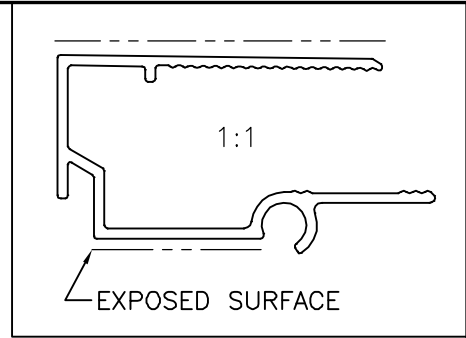

F = FULL RADIUS

 SYMBOL OF QUALITY AN ISO 9001 COMPANY	JINDAL ALUMINIUM LTD. BANGALORE-560073 (INDIA)	NAME	DATE
		DRAWN	J.P.KAUSHIK 26-03-2016
		CHECKED	
		APPROVED	S.S. GARG 30-03-2016
		SCALE	3:1
		AREA mm ²	179.243
		PERIMETER mm.	261.506
		WEIGHT kg/m	0.484
PARTY'S NAME	DAN PAL (INDIA) PRIVATE LTD., NEW DELHI	DRAWING No.	SECTION No.
PARTY'S DRAWING No.	AS PER AutoCAD DRAWING-DPI/UPD-16N/01/R-0	P-15716	-
ALLOY & TEMPER	6063 T5	S4892	S4892
		38633	38633
DESCRIPTION	ALUMINIUM UPD-16mm.		