

P-15680

X1976

38635

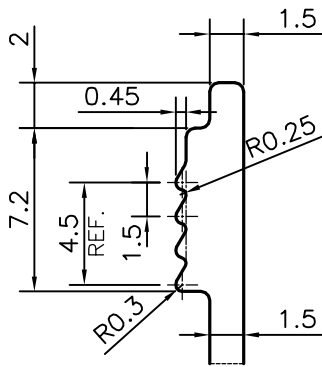
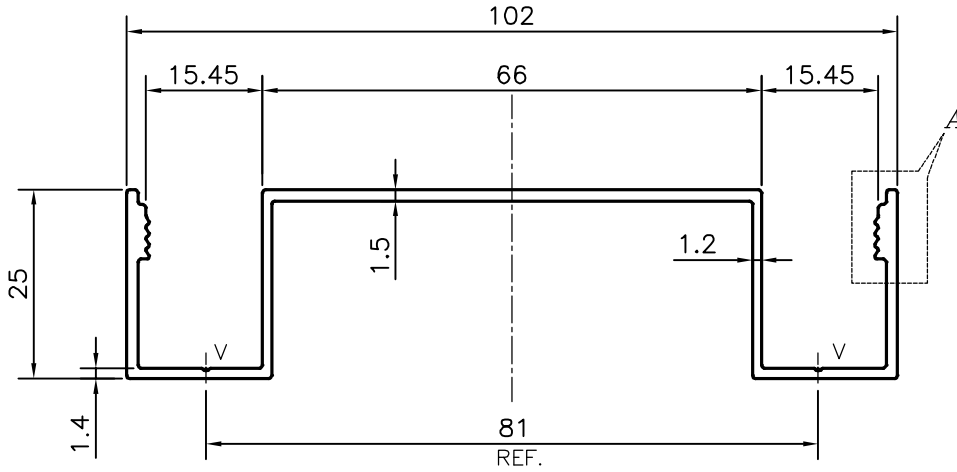

DETAIL OF "A"  
SCALE 3:1

V = VEE GROOVE 0.4x90° (2 PLACES)



SYMBOL OF QUALITY  
AN ISO 9001 COMPANY

**JINDAL ALUMINIUM LTD.**  
BANGALORE-560073 (INDIA)

|             | NAME            | DATE       |
|-------------|-----------------|------------|
| DRAWN       | PARVESH         | 17-03-2016 |
| CHECKED     |                 |            |
| APPROVED    | B. NATARAJ      | 25-03-2016 |
| SCALE       |                 | 1:1        |
| AREA        | mm <sup>2</sup> | 293.81     |
| PERIMETER   | mm.             | 399.276    |
| WEIGHT      | kg/m            | 0.793      |
| DRAWING No. | SECTION No.     |            |
| P-15680     | -               |            |
| X1976       | X1976           |            |
| 38635       | 38635           |            |
|             |                 |            |
|             |                 |            |

1. ALL DIMENSIONS ARE IN mm.
2. ROUND OFF ALL SHARP CORNERS WITH 0.40 mm.
3. TOLERANCES WILL BE AS PER IS:3965-1981 , UNLESS OTHERWISE SPECIFIED

|                     |                                    |
|---------------------|------------------------------------|
| PARTY'S NAME        | HYTEK INTERIOR PRODUCTS, BANGALORE |
| PARTY'S DRAWING No. | AS PER AUTOCAD DRAWING             |
| ALLOY & TEMPER      | HE9 WP                             |
| DESCRIPTION         | ARCHITECTURAL SECTION              |