

P-16057
S5059
38651

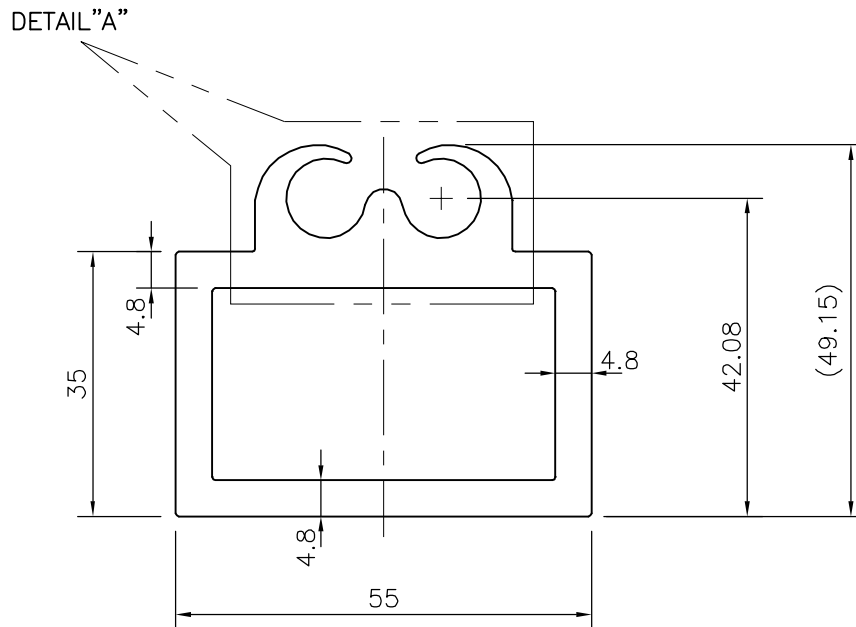
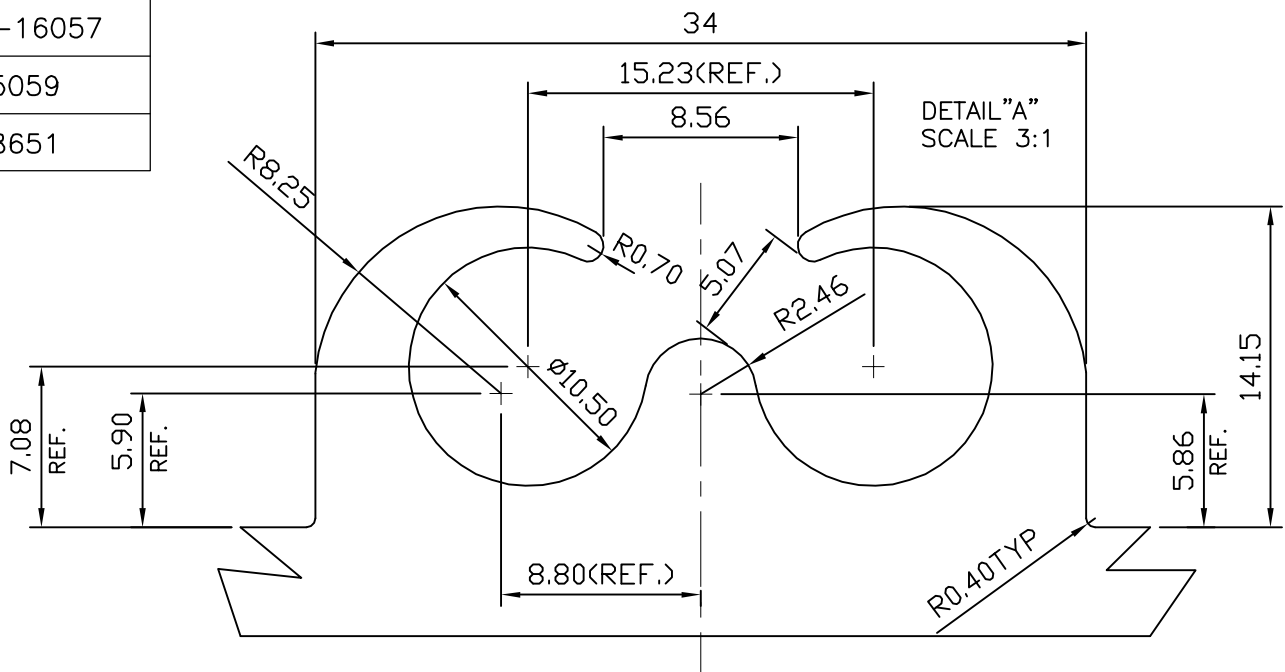

JINDAL ALUMINIUM LTD.
BANGALORE-560073 (INDIA)

	NAME	DATE
DRAWN	J.P.KAUSHIK	01-07-2016
CHECKED		
APPROVED	S.S. GARG	11-08-2016
SCALE		1:1
AREA mm ²		1000.66
PERIMETER mm.		255.315
WEIGHT kg/m		2.702
DRAWING No.	SECTION No.	
P-16057	-	
S5059	S5059	
38651	38651	

1. ALL DIMENSIONS ARE IN mm.
2. ROUND OFF ALL SHARP CORNERS WITH 0.40 mm.
3. TOLERANCES WILL BE AS PER IS:6477-1983 UNLESS OTHERWISE SPECIFIED

PARTY'S NAME	AUTOMOTIVE COACHES & COMPONENTS LTD., CHENNAI
PARTY'S DRAWING No.	AS PER DRAWING
ALLOY & TEMPER	6005 T6
DESCRIPTION	MISC. SECTION