

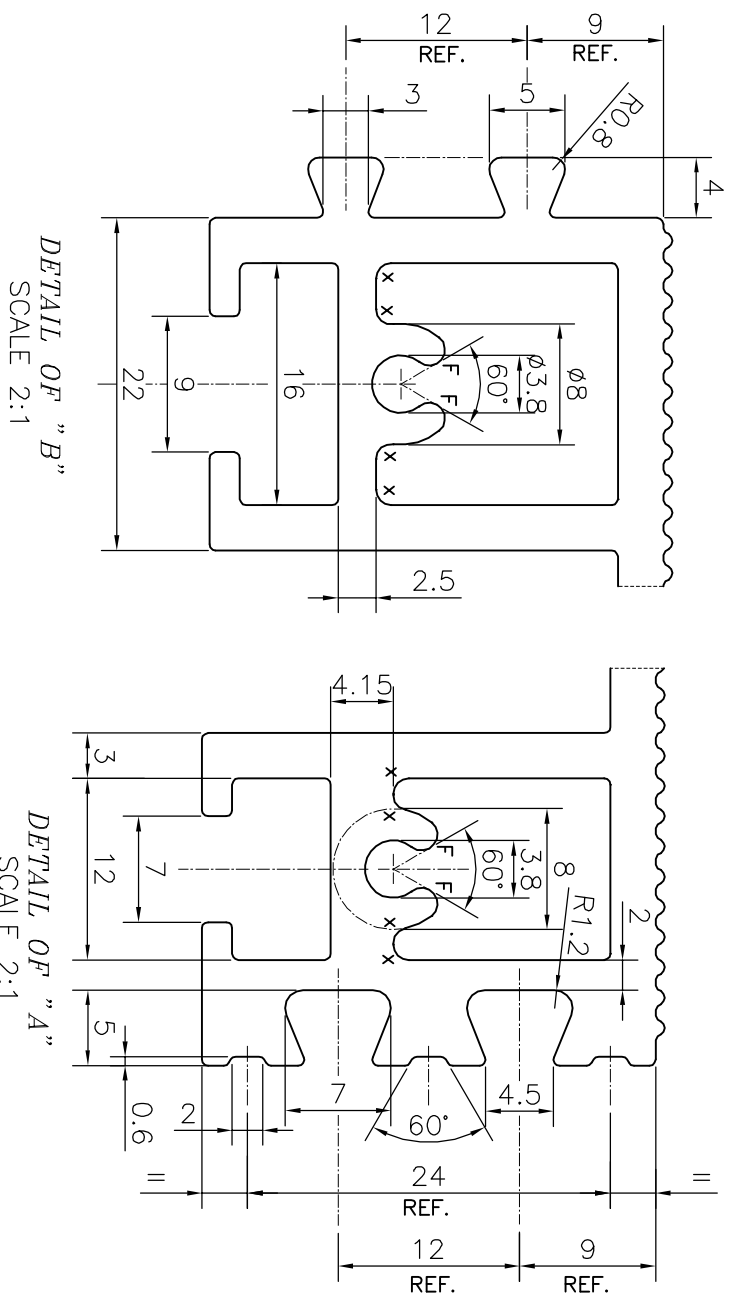

SCALE: - 1:1

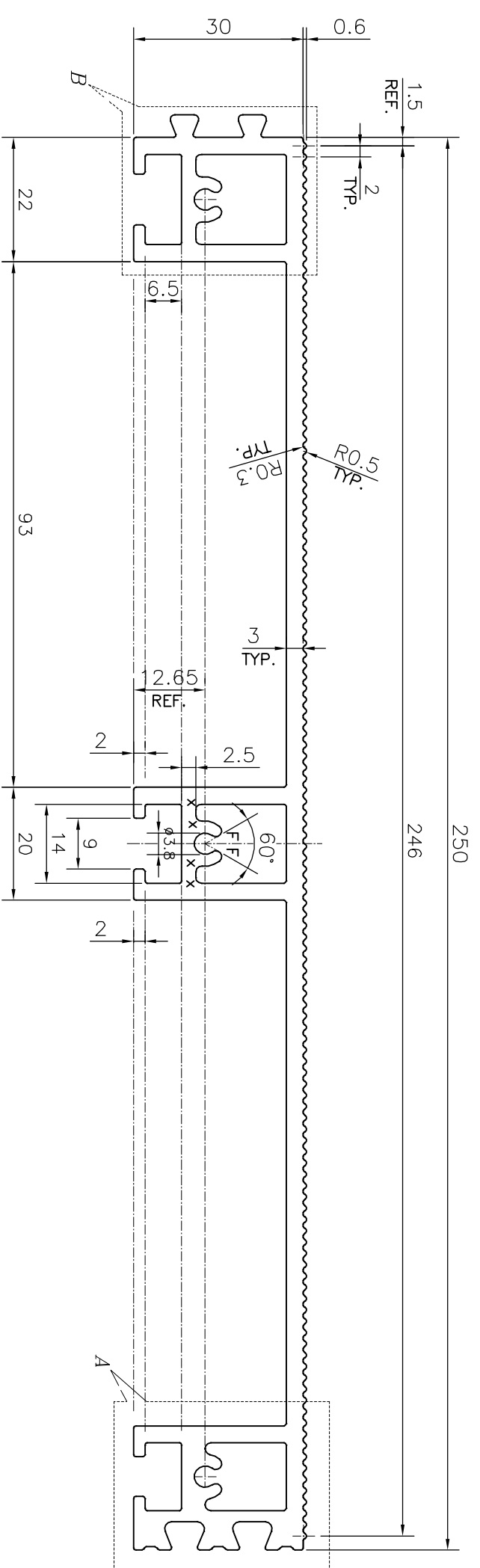

 <p>JINDAL ALUMINIUM LTD. BANGALORE-560073 (INDIA)</p>		<p>SYMBOL OF QUALITY AN ISO 9001 COMPANY</p>	<p>1. ALL DIMENSIONS ARE IN mm. 2. ROUND OFF ALL SHARP CORNERS WITH 0.40 mm. 3. TOLERANCES WILL BE AS PER IS:6477-1983 , UNLESS OTHERWISE SPECIFIED</p>
		<p>PARTY'S NAME WEST COAST ENGINEERING WORKS PVT. LTD., THANE</p>	<p>PARTY'S DRAWING No. AS PER DRAWING</p>
<p>ALLOY & TEMPER 6005 T6</p>	<p>DESCRIPTION MISC. SECTION</p>	<p>DRAWN PARVESH</p>	<p>DATE 25-01-2018</p>
<p>DESCRIPTION MISC. SECTION</p>	<p>DRAWING No. P-17810</p>	<p>CHECKED J.N.RAI</p>	<p>APPROVED 02-02-2018</p>
<p>DESCRIPTION MISC. SECTION</p>	<p>WEIGHT kg/m 4.283</p>	<p>AREA mm² 1586.412</p>	<p>PERIMETER mm. 854.827</p>
<p>DESCRIPTION MISC. SECTION</p>	<p>DRAWING No. S5649</p>	<p>SECTION No. -</p>	<p>SECTION No. -</p>
<p>DESCRIPTION MISC. SECTION</p>	<p>DRAWING No. 38655</p>	<p>SECTION No. -</p>	<p>SECTION No. -</p>