

P-15967

X2022

38658

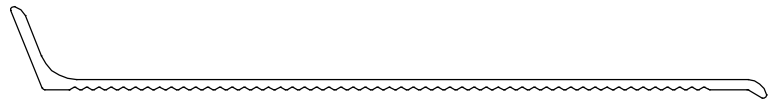

SCALE: - 1:1

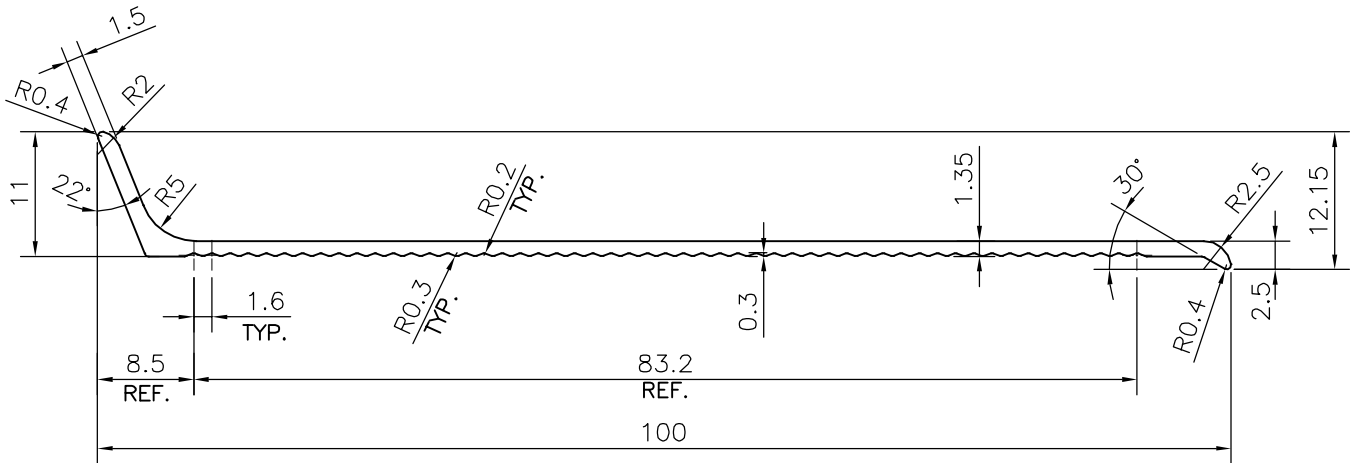

SYMBOL OF QUALITY
AN ISO 9001 COMPANY

JINDAL ALUMINIUM LTD.
BANGALORE-560073 (INDIA)

	NAME	DATE
DRAWN	PARVESH	18-06-2016
CHECKED		
APPROVED	S.S. GARG	01-07-2016

1. ALL DIMENSIONS ARE IN mm.
2. ROUND OFF ALL SHARP CORNERS WITH 0.40 mm.
3. TOLERANCES WILL BE AS PER IS:3965-1981, UNLESS OTHERWISE SPECIFIED

SCALE 1.5:1

AREA mm² 134.92

PERIMETER mm. 220.573

WEIGHT kg/m 0.364

PARTY'S NAME	FALANX FLOOR SOLUTIONS PVT. LTD., BANGALORE
PARTY'S DRAWING No.	AS PER REQUIREMENT
ALLOY & TEMPER	HE9 WP
DESCRIPTION	ARCHITECTURAL SECTION

DRAWING No. SECTION No.

P-15967 -

X2022 X2022

38658 38658