

P-19876

38686

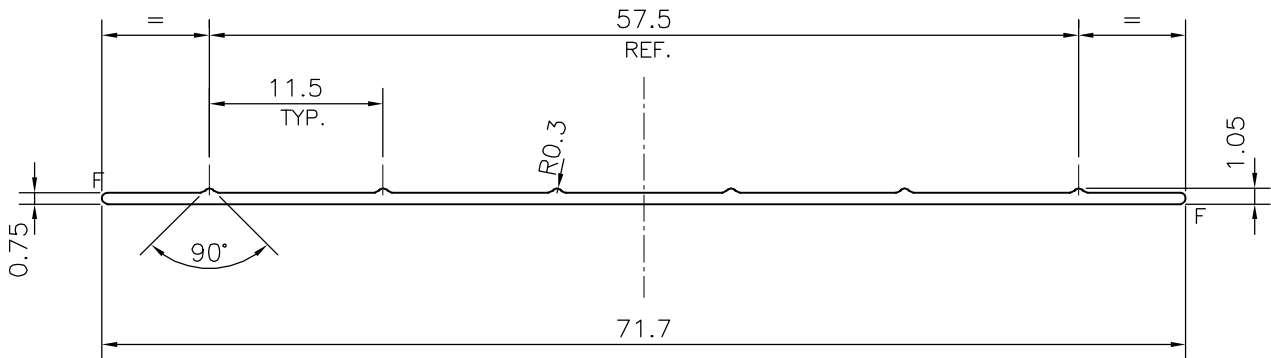

SCALE: - 1:1

F = FULL RADIUS (2 PLACES)

 SYMBOL OF QUALITY
AN ISO 9001 COMPANY

JINDAL ALUMINIUM LTD.
BANGALORE-560073 (INDIA)

	NAME	DATE
DRAWN	J.P.KAUSHIK	20-07-2019
CHECKED		
APPROVED	B.NATARAJA	24-07-2019

1. ALL DIMENSIONS ARE IN mm.
2. ROUND OFF ALL SHARP CORNERS WITH 0.40 mm.
3. TOLERANCES WILL BE AS PER IS:3965-1981 , UNLESS OTHERWISE SPECIFIED

SCALE	2:1
AREA mm ²	54.66
PERIMETER mm.	145.386
WEIGHT kg/m	0.148

PARTY'S NAME GENERAL CATEGORY, HYDERBAD MARKET

PARTY'S DRAWING No. AS PER SAMPLE & REQUIREMENT

ALLOY & TEMPER 6063 T6

DESCRIPTION ARCHITECTURAL SECTION

DRAWING No.	SECTION No.
P-19876	-
38686	38686