

P-21699

38732

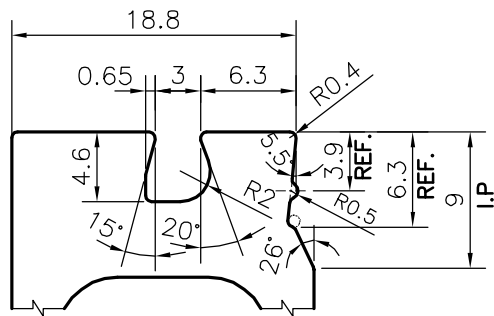

DETAIL OF "A"
SCALE:- 2:1

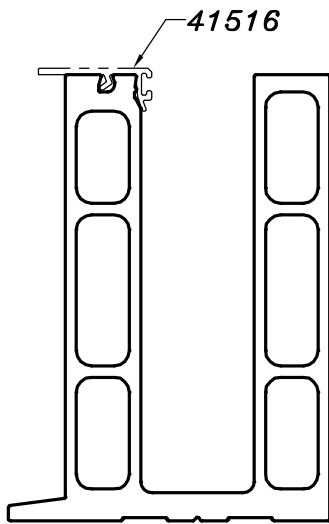

SCALE:- 0.5:1
ASSEMBLY

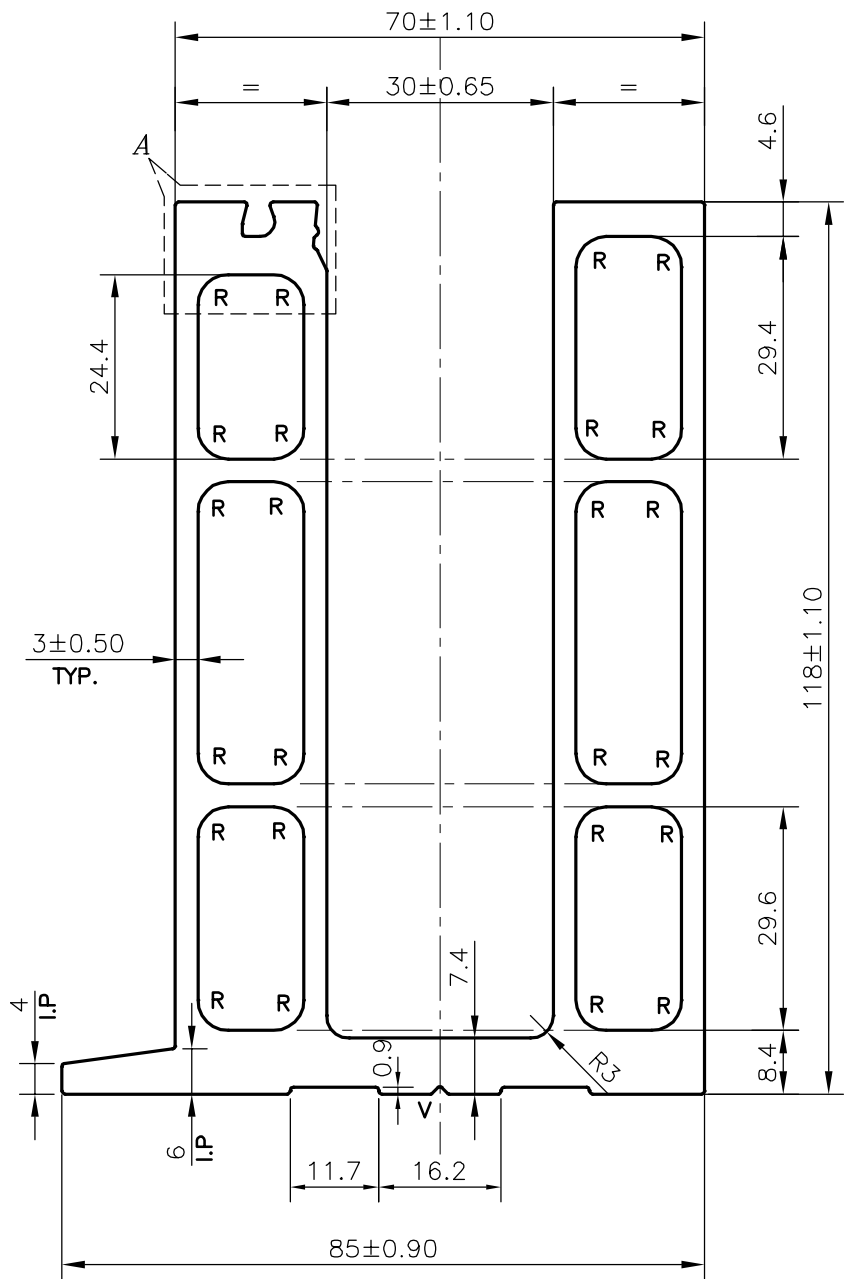

V="V" GROOVE 1x90° (1 PLACE)
R = 4 mm RADIUS (24 PLACES)

TOLERANCES ON OVERALL DIMENSIONS OF HOLLOW SECTIONS

UPTO 20.0mm - ±0.30	UPTO 80.0mm - ±0.70	UPTO 180.0mm - ±1.27	1. STRAIGHTNESS=1.7mm/M 2. TWIST=1.7mm/M 3. ANGULARITY= ±2° 4. FLATNESS =0.006xWIDTH
UPTO 30.0mm - ±0.38	UPTO 100.0mm - ±0.80	UPTO 200.0mm - ±1.40	
UPTO 40.0mm - ±0.45	UPTO 120.0mm - ±0.90	UPTO 225.0mm - ±1.52	
UPTO 50.0mm - ±0.52	UPTO 140.0mm - ±1.00		
UPTO 60.0mm - ±0.60	UPTO 160.0mm - ±1.14		



SYMBOL OF QUALITY
AN ISO 9001 COMPANY

JINDAL ALUMINIUM LTD.
BANGALORE-560073 (INDIA)

	NAME	DATE
DRAWN	DARPAN	13-10-2020
CHECKED		
APPROVED	B.NATARAJA	23-10-2020
SCALE		1:1
AREA mm ²		2351.242
PERIMETER mm.		633.517
WEIGHT kg/m		6.348
DRAWING No.		SECTION No.
P-21699		-
38732		38732

- ALL DIMENSIONS ARE IN mm.
- ROUND OFF ALL SHARP CORNERS WITH 0.40 mm.
- TOLERANCES WILL BE AS PER IS:6477-1983, UNLESS OTHERWISE SPECIFIED

PARTY'S NAME	VERTICAL FINE INDIA P. LTD., NOIDA
PARTY'S DRAWING No.	AS PER DRAWING
ALLOY & TEMPER	6063 T6
DESCRIPTION	STRUCTURAL MISC. SECTION