

P-21707

38737

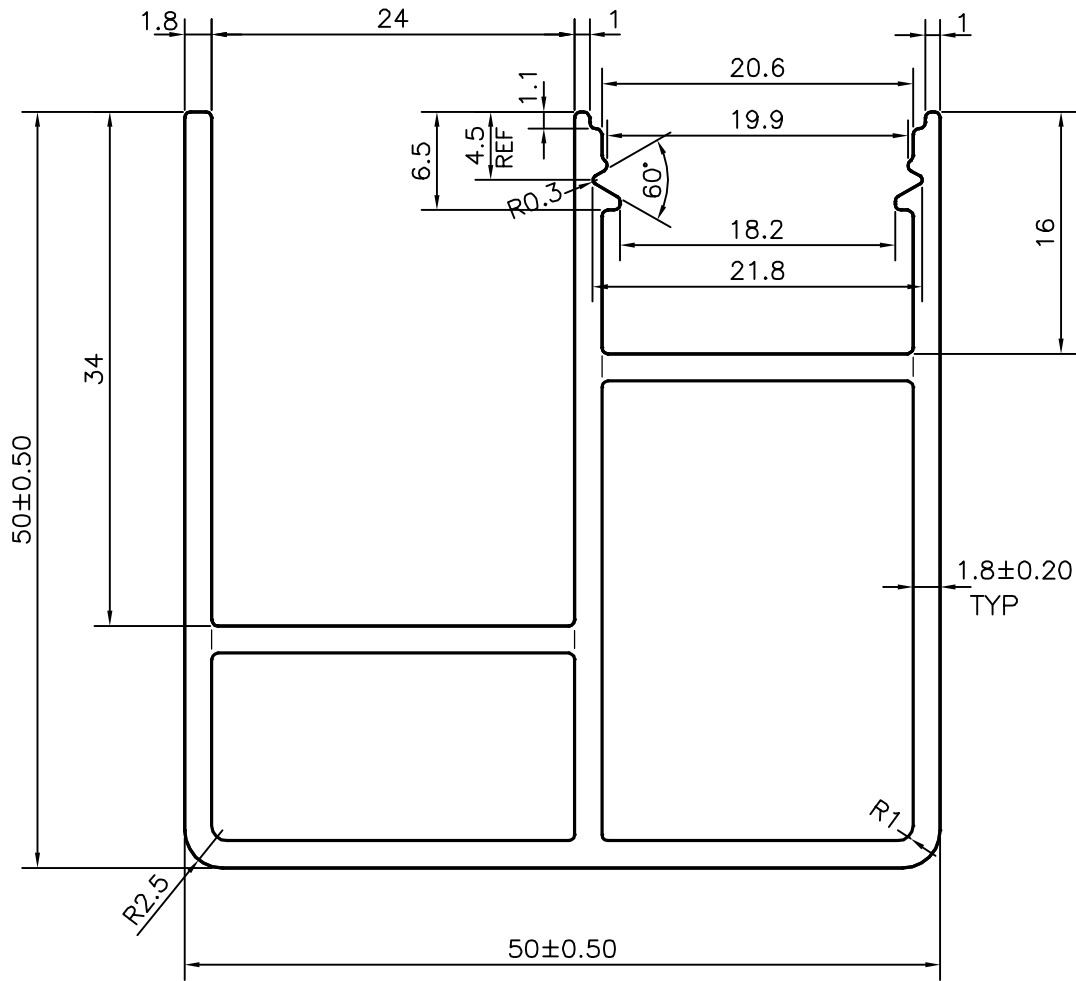

AVERAGE WEIGHT:-0.933 kg/m TO 1.166 kg/m

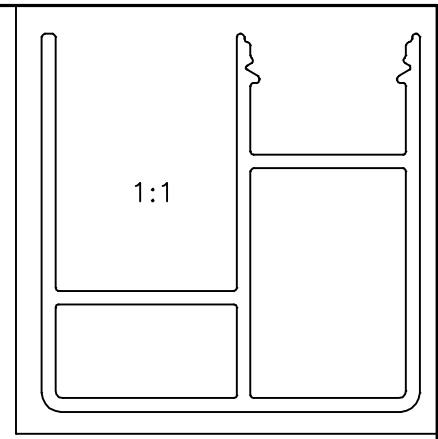

SYMBOL OF QUALITY
AN ISO 9001 COMPANY

JINDAL ALUMINIUM LTD.
BANGALORE-560073 (INDIA)

	NAME	DATE
DRAWN	J.P.KAUSHIK	21-10-2020
CHECKED		
APPROVED	B.NATARAJA	30-10-2020
SCALE		2:1
AREA mm ²		429.021
PERIMETER mm.		300.273
WEIGHT kg/m		1.158
DRAWING No.	SECTION No.	
P-21707	-	
38737	38737	

1. ALL DIMENSIONS ARE IN mm.
2. ROUND OFF ALL SHARP CORNERS WITH 0.40 mm.
3. TOLERANCES WILL BE AS PER IS:6477-1983 , UNLESS OTHERWISE SPECIFIED

PARTY'S NAME	VERTICAL FINE INDIA PVT. LTD., NOIDA
PARTY'S DRAWING No.	AS PER DRAWING
ALLOY & TEMPER	6063 T6
DESCRIPTION	MISC. SECTION