

P-18350
S5901
38743

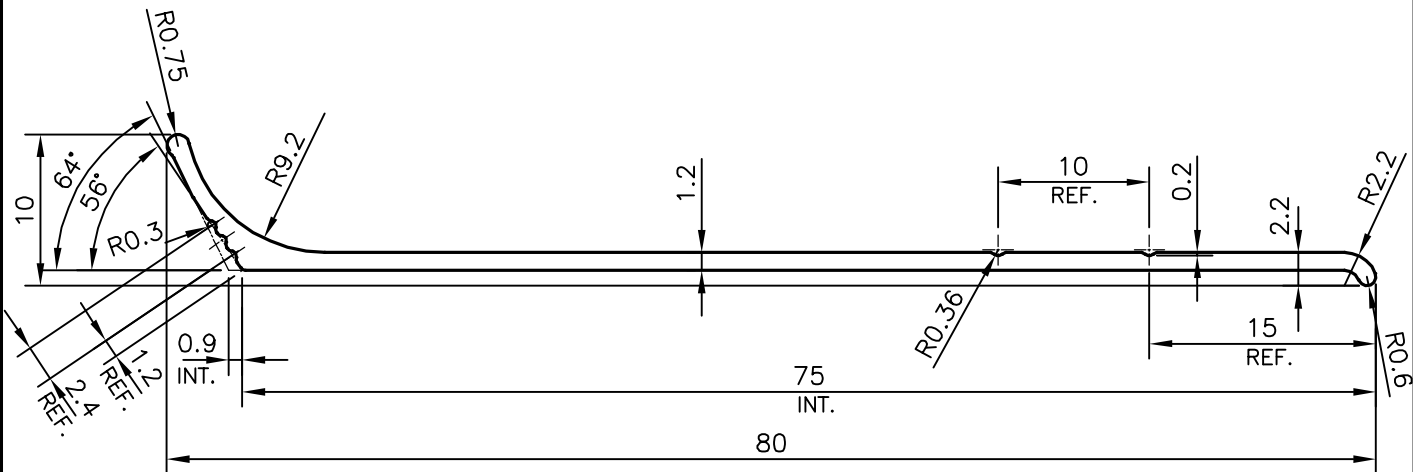
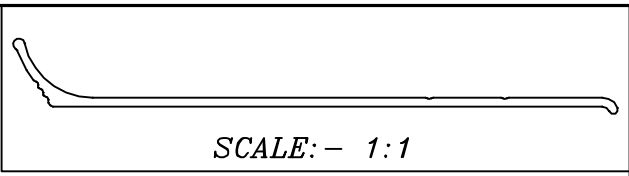

JINDAL ALUMINIUM LTD.
 BANGALORE-560073 (INDIA)

	NAME	DATE
DRAWN	PARVESH	26-06-2018
CHECKED		
APPROVED	B.NATARAJA	29-06-2018
SCALE		2:1
AREA	mm ²	104.12
PERIMETER	mm.	171.153
WEIGHT	kg/m	0.281
DRAWING No.	SECTION No.	
P-18350	-	
S5901	S5901	
38743	38743	

1. ALL DIMENSIONS ARE IN mm. 2. ROUND OFF ALL SHARP CORNERS WITH 0.4 mm. 3. TOLERANCES WILL BE AS PER IS:3965-1981 , UNLESS OTHERWISE SPECIFIED	
PARTY'S NAME	ALUCRAFT, BANGALORE
PARTY'S DRAWING No.	AS PER AUTOCAD DRAWING-03 (80 mm.)
ALLOY & TEMPER	6063 T6
DESCRIPTION	ARCHITECTURAL SECTION-SKIRTING