

P-18351

S5902

38744

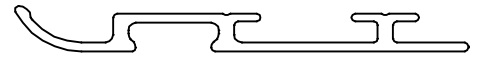

SCALE:- 1:1

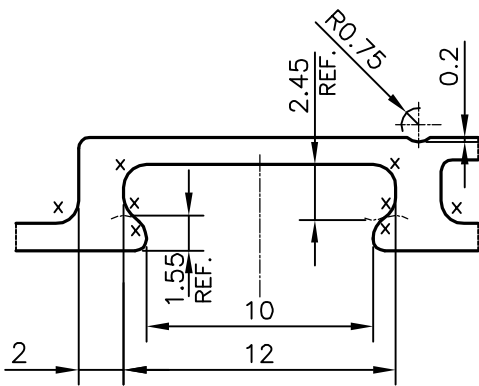
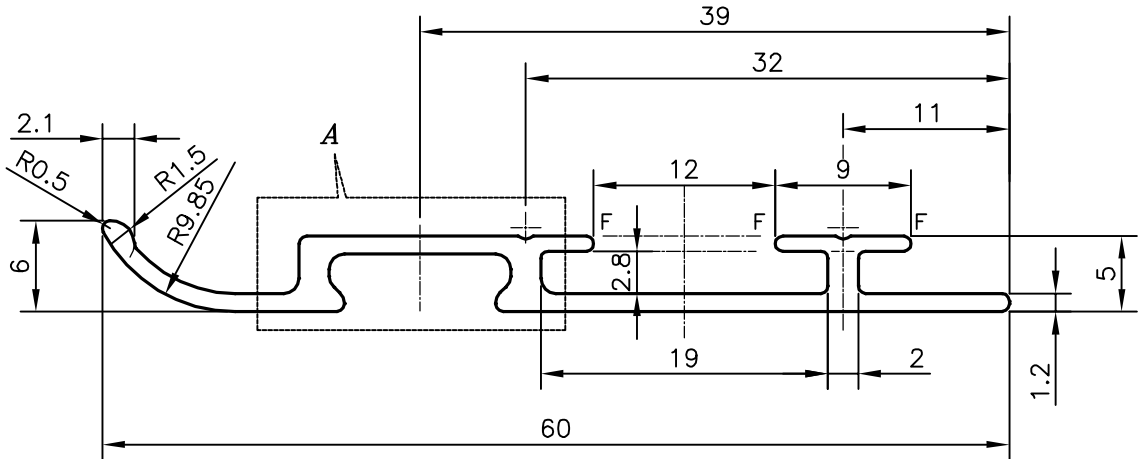

DETAIL OF "A"  
SCALE 3:1

F = FULL RADIUS (3 PLACES)  
X = RADIUS 1 mm. (8 PLACES)

ROUND OFF ALL SHARP CORNERS WITH 0.5 mm.



SYMBOL OF QUALITY  
AN ISO 9001 COMPANY

**JINDAL ALUMINIUM LTD.**  
BANGALORE-560073 (INDIA)

	NAME	DATE
DRAWN	PARVESH	26-06-2018
CHECKED		
APPROVED	B.NATARAJA	29-06-2018
SCALE		2:1
AREA	mm <sup>2</sup>	110.932
PERIMETER	mm.	167.13
WEIGHT	kg/m	0.300
DRAWING No.	SECTION No.	
P-18351	-	
S5902	S5902	
38744	38744	

1. ALL DIMENSIONS ARE IN mm.
2. ROUND OFF ALL SHARP CORNERS WITH 0.4 mm.
3. TOLERANCES WILL BE AS PER IS:3965-1981 , UNLESS OTHERWISE SPECIFIED

PARTY'S NAME	ALUCRAFT, BANGALORE
PARTY'S DRAWING No.	AS PER AUTOCAD DRAWING-02 (60 mm.)
ALLOY & TEMPER	6063 T6
DESCRIPTION	ARCHITECTURAL SECTION-SKIRTING