

P-18353

S5904

38746

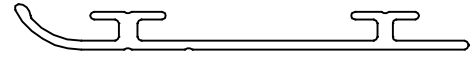

SCALE:- 1:1

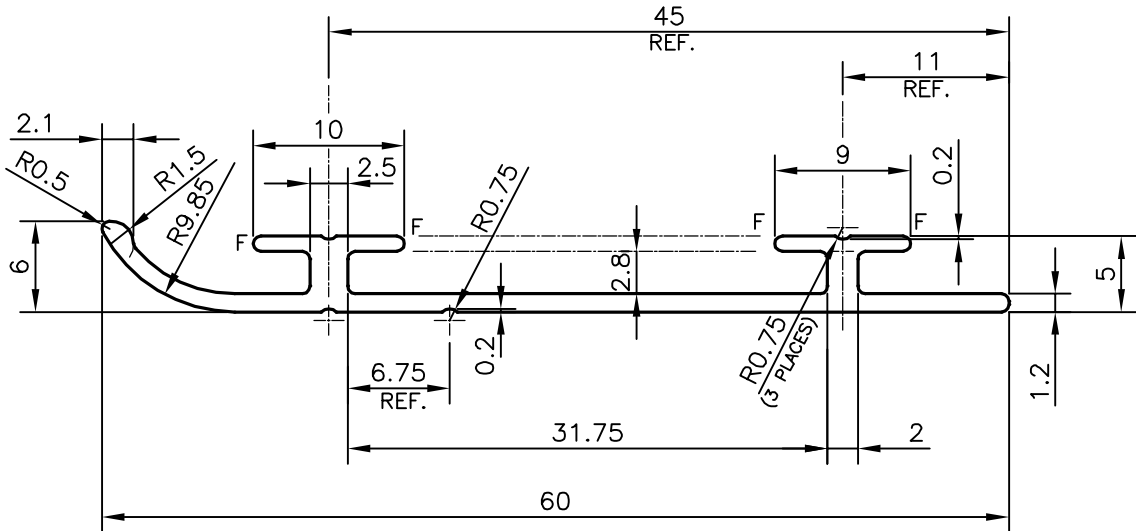

F = FULL RADIUS (4 PLACES)

ROUND OFF ALL SHARP CORNERS WITH 0.5 mm.



SYMBOL OF QUALITY
AN ISO 9001 COMPANY

JINDAL ALUMINIUM LTD.
BANGALORE-560073 (INDIA)

	NAME	DATE
DRAWN	PARVESH	26-06-2018
CHECKED		
APPROVED	B.NATARAJA	29-06-2018
SCALE		2:1
AREA	mm ²	105.408
PERIMETER	mm.	166.347
WEIGHT	kg/m	0.285
DRAWING No.	SECTION No.	
P-18353	-	
S5904	S5904	
38746	38746	

1. ALL DIMENSIONS ARE IN mm.
2. ROUND OFF ALL SHARP CORNERS WITH 0.4 mm.
3. TOLERANCES WILL BE AS PER IS:3965-1981 , UNLESS OTHERWISE SPECIFIED

PARTY'S NAME	ALUCRAFT, BANGALORE
PARTY'S DRAWING No.	AS PER AUTOCAD DRAWING-01 (60 mm.)
ALLOY & TEMPER	6063 T6
DESCRIPTION	ARCHITECTURAL SECTION-SKIRTING