

P-18354

S5905

38747

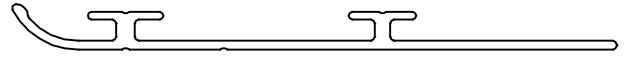

SCALE:- 1:1

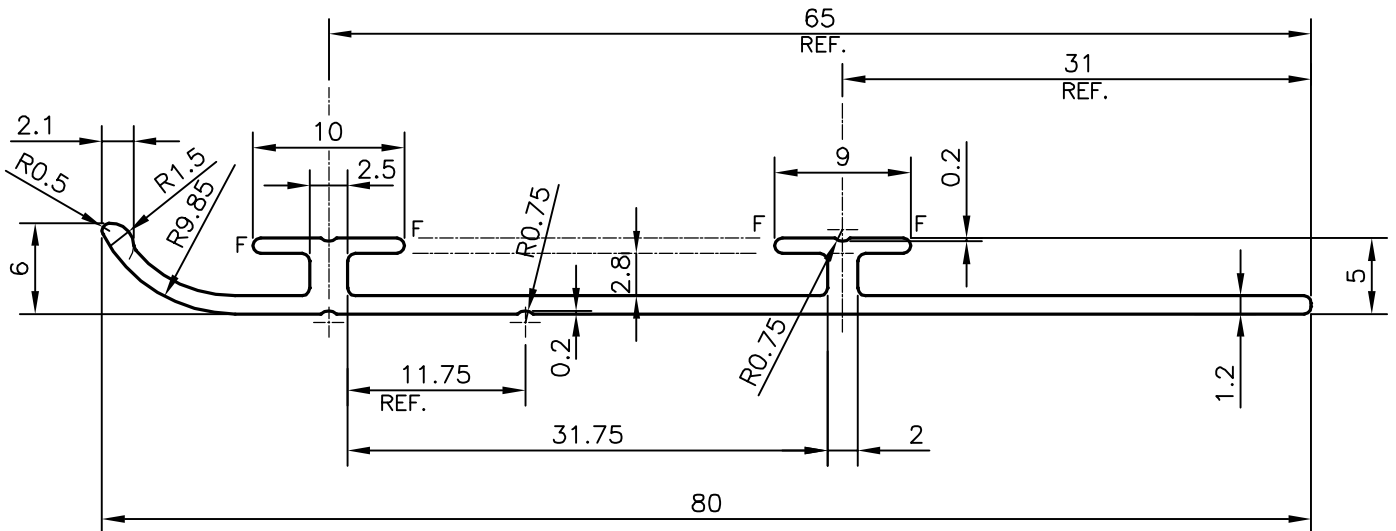

F = FULL RADIUS (4 PLACES)

ROUND OFF ALL SHARP CORNERS WITH 0.5 mm.

SYMBOL OF QUALITY  
AN ISO 9001 COMPANY**JINDAL ALUMINIUM LTD.**  
BANGALORE-560073 (INDIA)

	NAME	DATE
DRAWN	PARVESH	26-06-2018
CHECKED		
APPROVED	B.NATARAJA	29-06-2018
SCALE		2:1
AREA mm <sup>2</sup>		129.408
PERIMETER mm.		206.347
WEIGHT kg/m		0.349
DRAWING No.		SECTION No.
P-18354		-
S5905		S5905
38747		38747

1. ALL DIMENSIONS ARE IN mm.
2. ROUND OFF ALL SHARP CORNERS WITH 0.4 mm.
3. TOLERANCES WILL BE AS PER IS:3965-1981 , UNLESS OTHERWISE SPECIFIED

PARTY'S NAME	ALUCRAFT, BANGALORE
PARTY'S DRAWING No.	AS PER AUTOCAD DRAWING-01 (80 mm.)
ALLOY & TEMPER	6063 T6
DESCRIPTION	ARCHITECTURAL SECTION-SKIRTING