

P-21727

38752

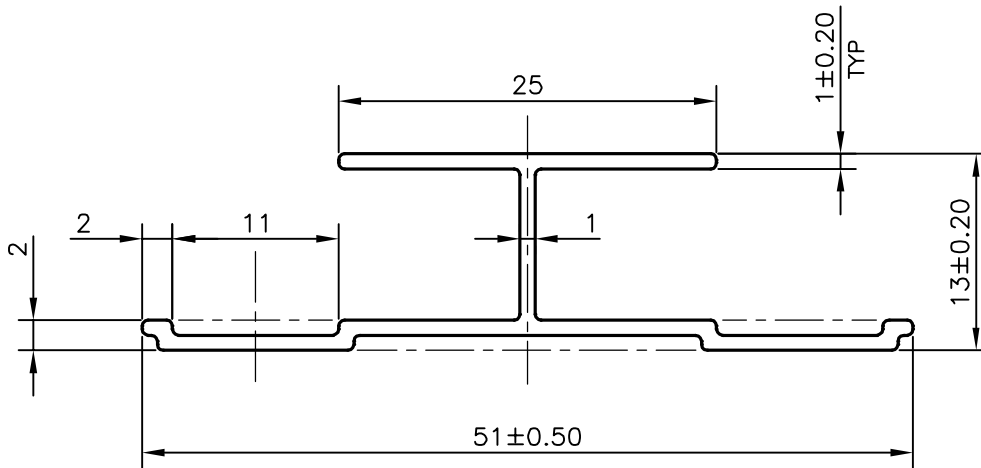

AVERAGE WEIGHT: -0.194 kg/m TO 0.291 kg/m

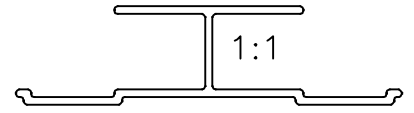

SYMBOL OF QUALITY
AN ISO 9001 COMPANY

JINDAL ALUMINIUM LTD.
BANGALORE-560073 (INDIA)

	NAME	DATE
DRAWN	J.P.KAUSHIK	29-10-2020
CHECKED		
APPROVED	B.NATARAJA	04-11-2020

1. ALL DIMENSIONS ARE IN mm.
2. ROUND OFF ALL SHARP CORNERS WITH 0.40 mm.
3. TOLERANCES WILL BE AS PER IS:3965-1981 UNLESS OTHERWISE SPECIFIED

SCALE	2:1
AREA mm ²	89.863
PERIMETER mm.	177.193
WEIGHT kg/m	0.243

PARTY'S NAME KOOL PACK & ALLIED INDUSTRIES, SOLAN

DRAWING No. SECTION No.

PARTY'S DRAWING No. AS PER DRAWING

P-21727

-

ALLOY & TEMPER 6063 T6

38752

38752

DESCRIPTION MISC. SECTION