

P-21620

38757

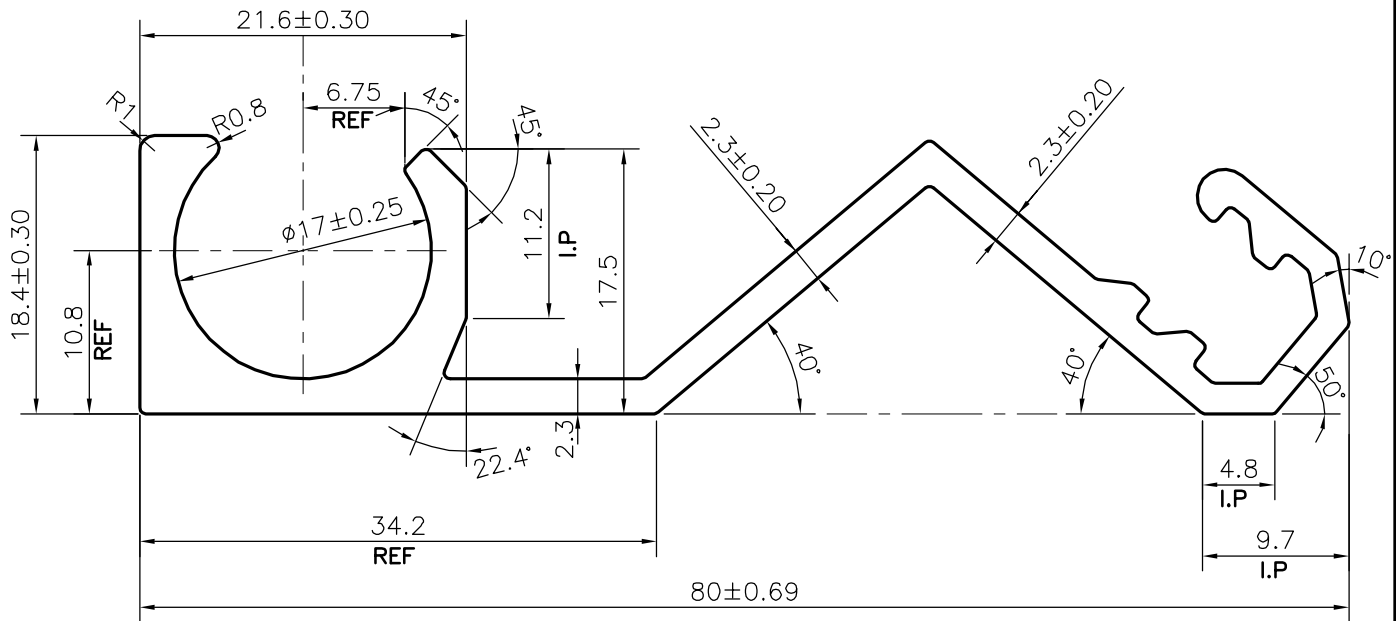
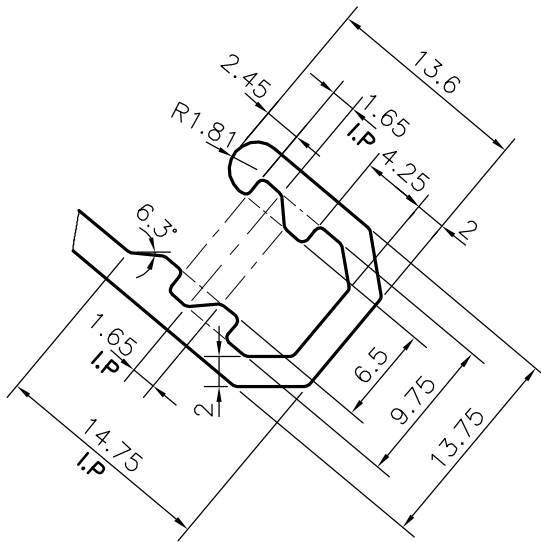
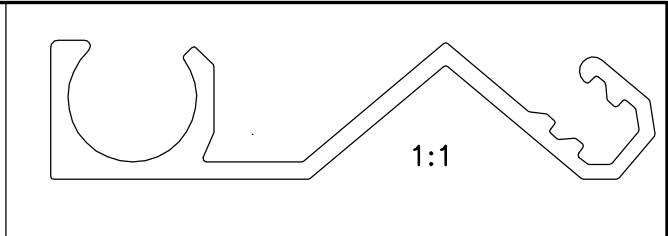

SYMBOL OF QUALITY
AN ISO 9001 COMPANY

JINDAL ALUMINIUM LTD.
BANGALORE-560073 (INDIA)

	NAME	DATE
DRAWN	J.P.KAUSHIK	03-10-2020
CHECKED		
APPROVED	B.NATARAJA	24-11-2020
SCALE		2:1
AREA mm ²		359.225
PERIMETER mm.		282.845
WEIGHT kg/m		0.970
DRAWING No.	SECTION No.	
P-21620	-	
38757	38757	

1. ALL DIMENSIONS ARE IN mm.
2. ROUND OFF ALL SHARP CORNERS WITH 0.40 mm.
3. TOLERANCES WILL BE AS PER, IS:3965-1981 UNLESS OTHERWISE SPECIFIED

PARTY'S NAME	SANFIELD (INDIA) LTD., BHOPAL
PARTY'S DRAWING No.	AS PER DRAWING
ALLOY & TEMPER	6063 T6
DESCRIPTION	MISC. SECTION