

P-21784-1

38763

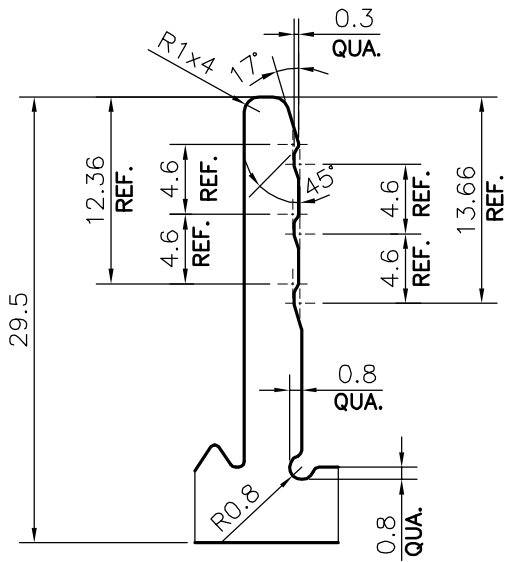

SCALE:- 2:1  
DETAIL OF "A"

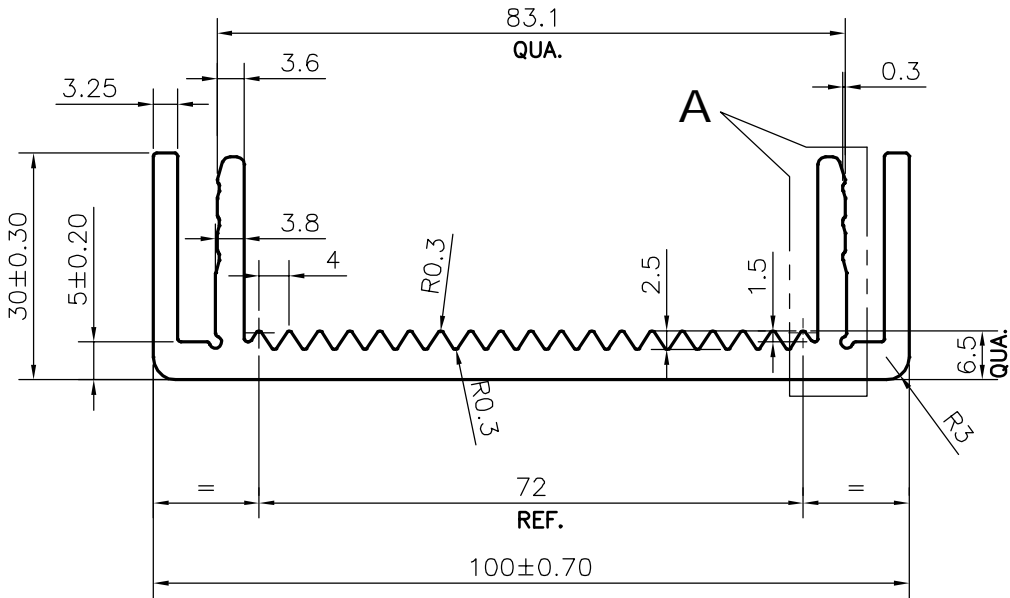
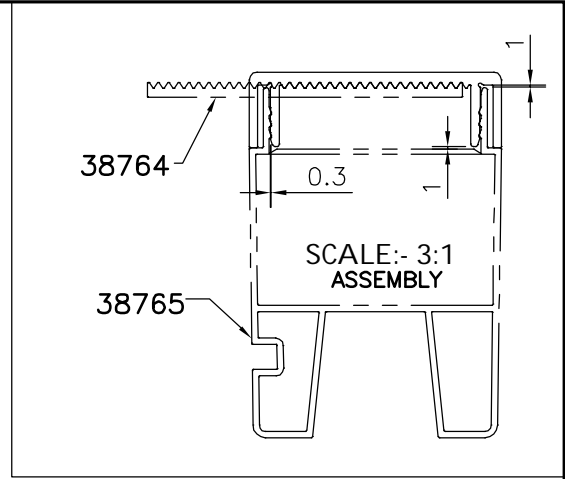

APPROXIMATE WEIGHT RANGE - 2.064 - 2.522 kg/m



SYMBOL OF QUALITY  
AN ISO 9001 COMPANY

**JINDAL ALUMINIUM LTD.**  
BANGALORE-560073 (INDIA)

	NAME	DATE
DRAWN	DARPAN	05-12-2020
CHECKED		
APPROVED	B.NATARAJA	10-12-2020
SCALE		1:1
AREA mm <sup>2</sup>		849.413
PERIMETER mm.		453.096
WEIGHT kg/m		2.293

1. ALL DIMENSIONS ARE IN mm.
2. ROUND OFF ALL SHARP CORNERS WITH 0.40 mm.
3. TOLERANCES WILL BE AS PER IS:3965-1981 UNLESS OTHERWISE SPECIFIED

PARTY'S NAME	DURALL SYSTEMS INDIA PVT. LTD., MUMBAI	DRAWING No.	P-21784-1	SECTION No.	-
PARTY'S DRAWING No.	NIB 02 REV. R1		38763		38763
ALLOY & TEMPER	6063 T6				
DESCRIPTION	NIB PROFILE ADAPTOR				