

P-21785

38764

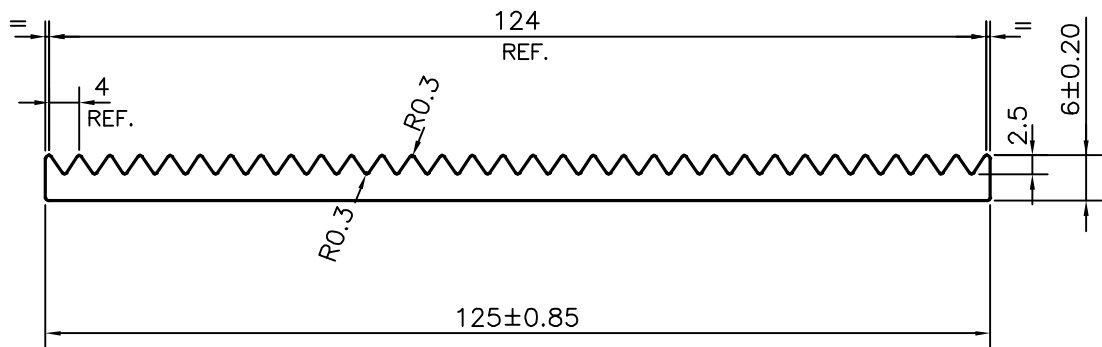

APPROXIMATE WEIGHT RANGE -1.512 kg/m TO 1.700 kg/m

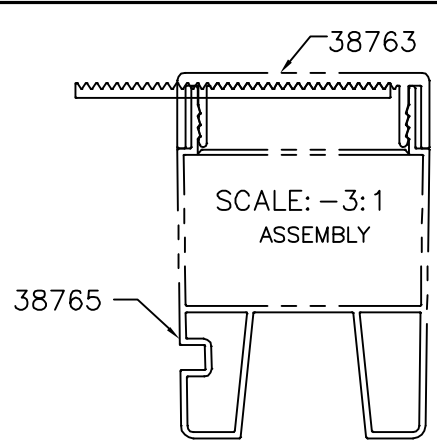
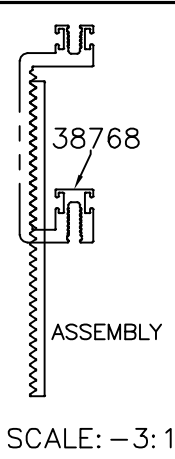
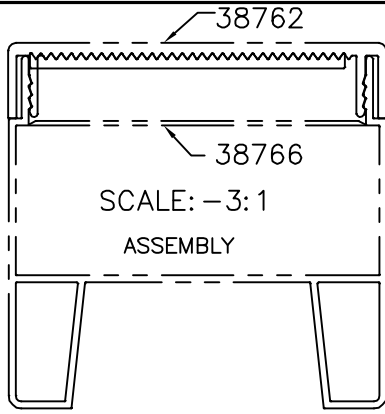

SYMBOL OF QUALITY  
AN ISO 9001 COMPANY

**JINDAL ALUMINIUM LTD.**  
BANGALORE-560073 (INDIA)

	NAME	DATE
DRAWN	J.P.KAUSHIK	21-11-2020
CHECKED		
APPROVED	B.NATARAJA	10-12-2020
SCALE		1:1
AREA	mm <sup>2</sup>	594.863
PERIMETER	mm.	340.673
WEIGHT	kg/m	1.606
DRAWING No.	SECTION No.	
P-21785	-	
38764	38764	

1. ALL DIMENSIONS ARE IN mm.
2. ROUND OFF ALL SHARP CORNERS WITH 0.40 mm.
3. TOLERANCES WILL BE AS PER IS:3965-1981 UNLESS OTHERWISE SPECIFIED

PARTY'S NAME	DURALL SYSTEM INDIA PVT. LTD., MUMBAI
PARTY'S DRAWING No.	SR01 REV. R1
ALLOY & TEMPER	6005 T6
DESCRIPTION	DUCT FIN (SERRATED PLATE)