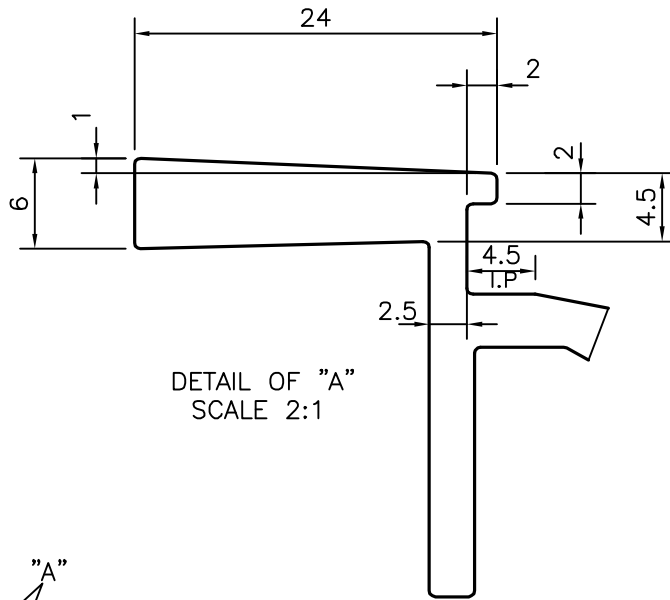
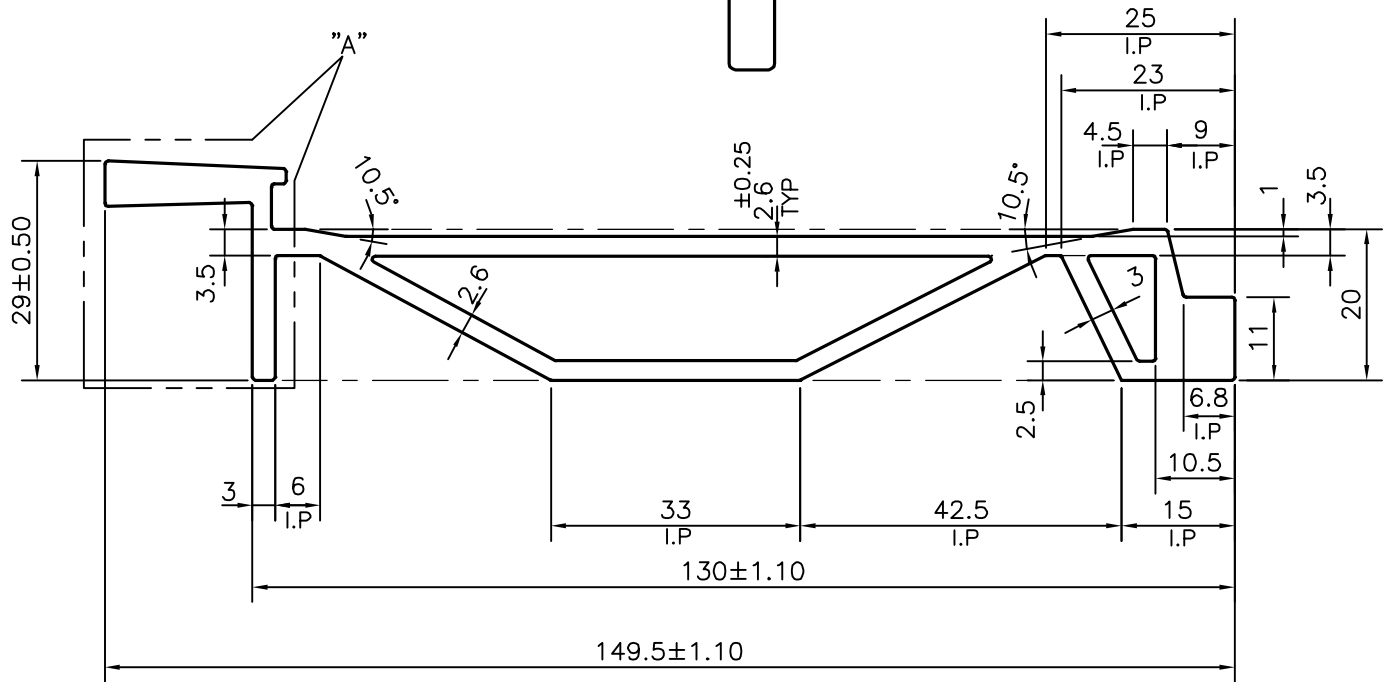

P-21713

38770

DETAIL OF "A"  
SCALE 2:1

APPROXIMATE WEIGHT RANGE - 2.329 - 2.825 kg/m

SYMBOL OF QUALITY  
AN ISO 9001 COMPANY**JINDAL ALUMINIUM LTD.**  
BANGALORE-560073 (INDIA)

|           | NAME            | DATE       |
|-----------|-----------------|------------|
| DRAWN     | J.P.KAUSHIK     | 24-10-2020 |
| CHECKED   |                 |            |
| APPROVED  | B.NATARAJA      | 16-12-2020 |
| SCALE     |                 | 1:1        |
| AREA      | mm <sup>2</sup> | 954.496    |
| PERIMETER | mm.             | 391.419    |
| WEIGHT    | kg/m            | 2.577      |

- ALL DIMENSIONS ARE IN mm.
- ROUND OFF ALL SHARP CORNERS WITH 0.40 mm.
- TOLERANCES WILL BE AS PER IS:6477-1983 UNLESS OTHERWISE SPECIFIED

|                     |  |
|---------------------|--|
| PARTY'S NAME        | TEJUS CENTERING & CONST EQUIP. PVT. LTD., PUNE |
| PARTY'S DRAWING No. | AS PER DRAWING                                 |
| ALLOY & TEMPER      | 6082 T6  |
| DESCRIPTION         | MISC. SECTION                                  |

| DRAWING No. | SECTION No. |
|-------------|-------------|
| P-21713     | -           |
| 38770       | 38770       |