

P-21714

38771

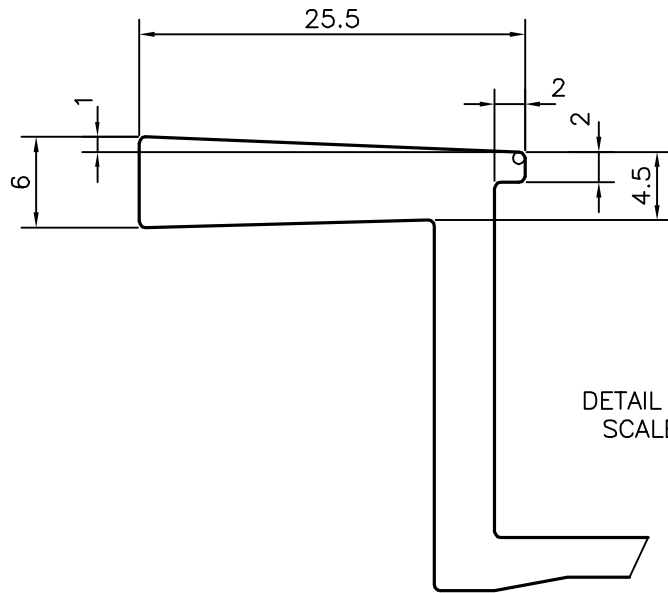

DETAIL OF "A"  
SCALE 2:1

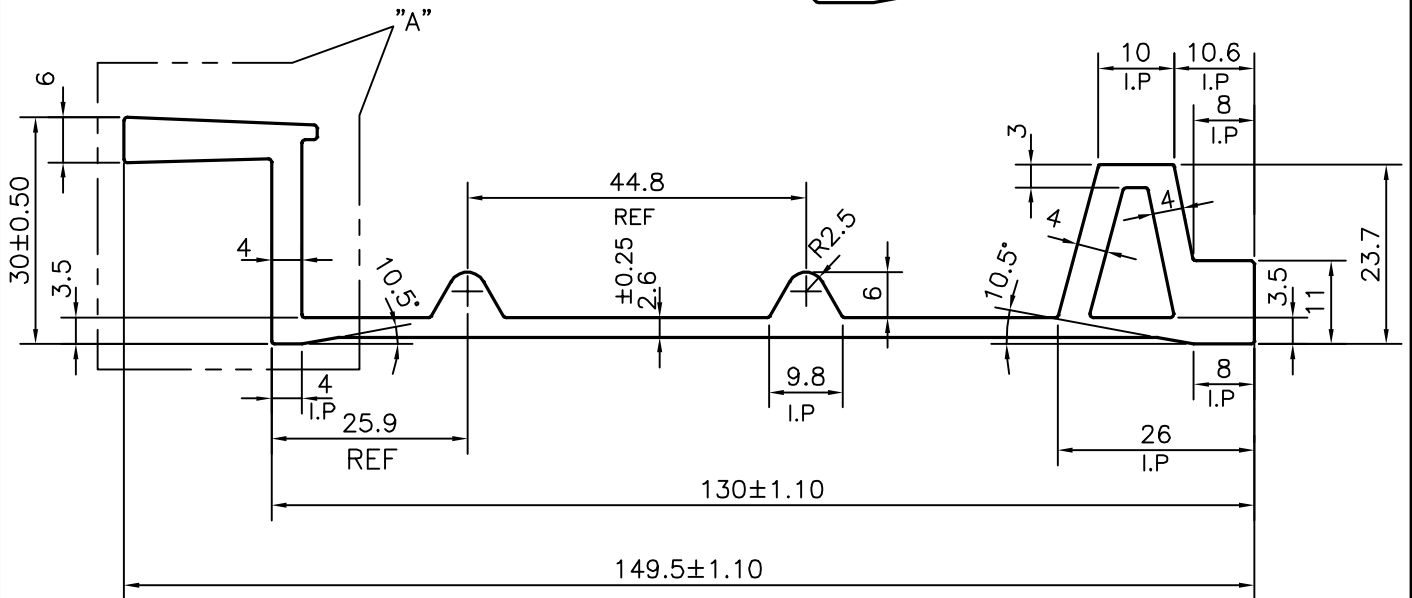

APPROXIMATE WEIGHT RANGE - 2.116 - 2.566 kg/m



SYMBOL OF QUALITY  
AN ISO 9001 COMPANY

**JINDAL ALUMINIUM LTD.**  
BANGALORE-560073 (INDIA)

	NAME	DATE
DRAWN	J.P.KAUSHIK	24-10-2020
CHECKED		
APPROVED	B.NATARAJA	16-12-2020
SCALE		1:1
AREA	mm <sup>2</sup>	867.211
PERIMETER	mm.	406.58
WEIGHT	kg/m	2.341
DRAWING No.	SECTION No.	
P-21714	-	
38771	38771	

- ALL DIMENSIONS ARE IN mm.
- ROUND OFF ALL SHARP CORNERS WITH 0.40 mm.
- TOLERANCES WILL BE AS PER IS:6477-1983 UNLESS OTHERWISE SPECIFIED

PARTY'S NAME	TEJUS CENTERING & CONST EQUIP. PVT. LTD., PUNE
PARTY'S DRAWING No.	AS PER DRAWING
ALLOY & TEMPER	6082 T6
DESCRIPTION	MISC. SECTION