

P-22993-1

38829

1:1

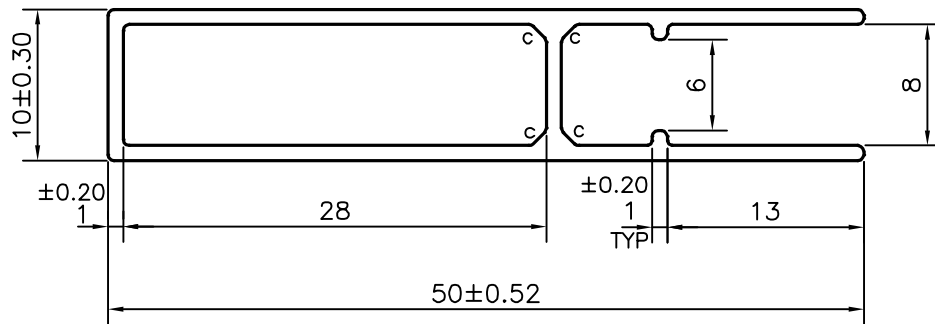

c = CHAMFER 1x45° (4 PLACES)

1. STRAIGHTNESS=1.7mm/M
2. TWIST=1.7mm/M
3. ANGULARITY= ±2°
4. FLATNESS =0.007xWIDTH

APPROXIMATE WEIGHT RANGE -0.292 - 0.356 kg/m



SYMBOL OF QUALITY
AN ISO 9001 COMPANY

JINDAL ALUMINIUM LTD.
BANGALORE-560073 (INDIA)

	NAME	DATE
DRAWN	J.P.KAUSHIK	24-09-2021
CHECKED		
APPROVED	B.NATARAJA	01-10-2021
SCALE		2:1
AREA mm ²		119.83
PERIMETER mm.		160.528
WEIGHT kg/m		0.324
DRAWING No.		SECTION No.
P-22993-1		-
38829		38829

1. ALL DIMENSIONS ARE IN mm.
2. ROUND OFF ALL SHARP CORNERS WITH 0.40 mm.
3. TOLERANCES WILL BE AS PER IS:6477-1983 , UNLESS OTHERWISE SPECIFIED

PARTY'S NAME	FAMELINE ARCHITECTURAL PRODUCTS PVT. LTD., BANGALORE
PARTY'S DRAWING No.	AS PER DRAWING
ALLOY & TEMPER	6063 T6
DESCRIPTION	ARCHITECTURAL SECTION