

IAL-D-6740

38852

38850

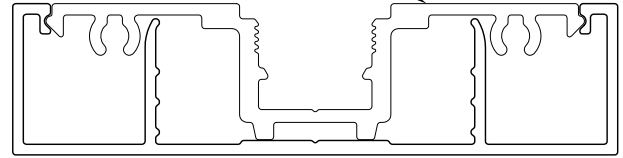

SCALE 1:1

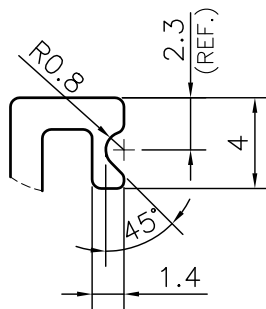
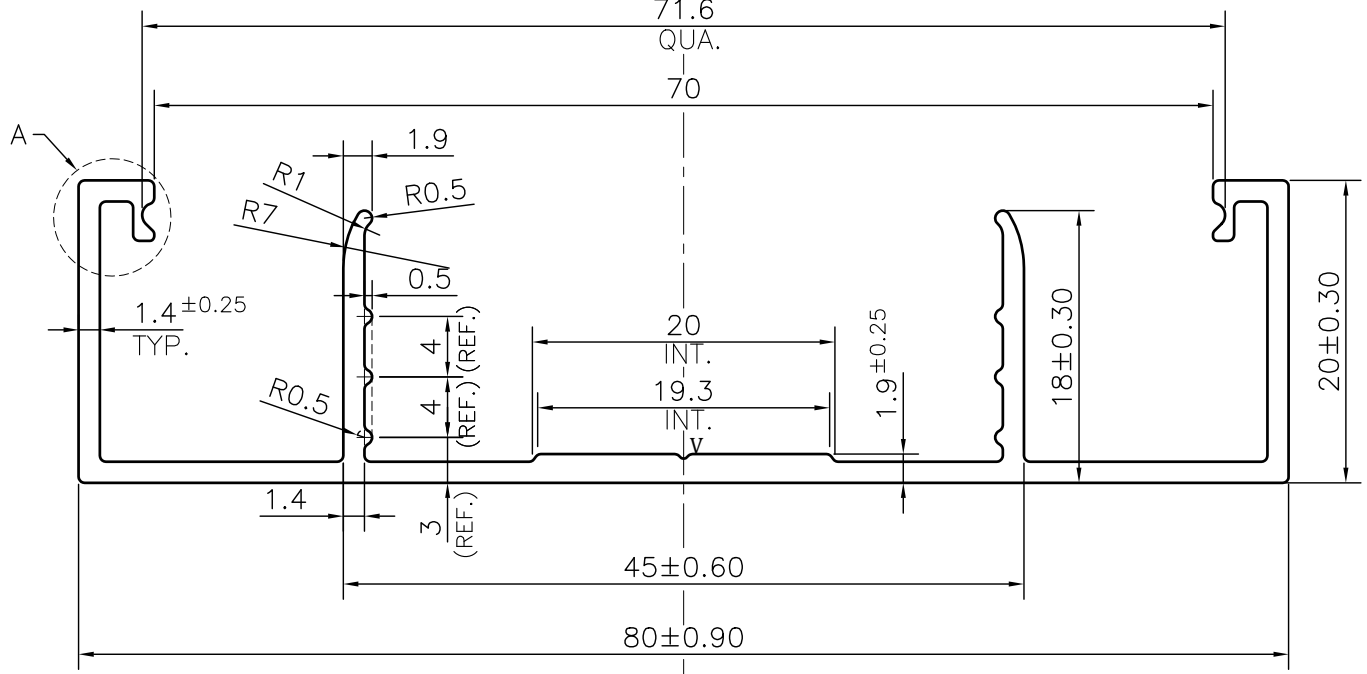
71.6
QUA.
70DETAIL A
SCALE 3:1**NOTE:-**
V= 0.3x90° V-GROOVE (1 PLACE)

1. STRAIGHTNESS= 1.7mm/M
2. TWIST= 1.7mm/M
3. ANGULARITY= ±2°
4. FLATNESS= 0.007xWIDTH

SYMBOL OF QUALITY
AN ISO 9001 COMPANY**JINDAL ALUMINIUM LTD.**
BHIWADI-301019 (INDIA)

	NAME	DATE
DRAWN	ASHUTOSH	17-01-2024

CHECKED

APPROVED

SCALE

2:1

AREA mm²

236.064

PERIMETER mm.

328.16

WEIGHT kg/m

0.637

DRAWING No.

SECTION No.

PARTY'S NAME

PERFECT SOLUTIONS

PARTY'S DRAWING No.

AS PER DRAWING

IAL-D-6740

-

ALLOY & TEMPER

6063 T6

PRODUCT CODE:-056

HSN CODE:- 76042990

38852

38852

DESCRIPTION

ARCHITECTURAL MISC. SECTION