

IAL-D-4990

38856

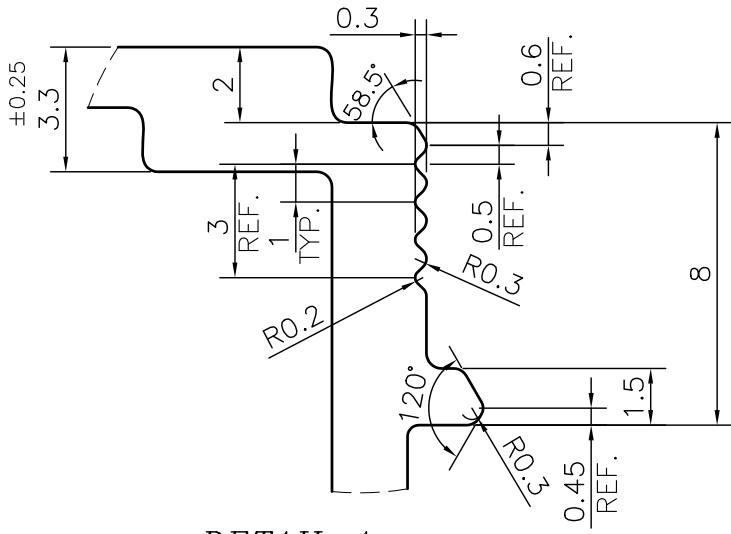

DETAIL A
SCALE 5:1

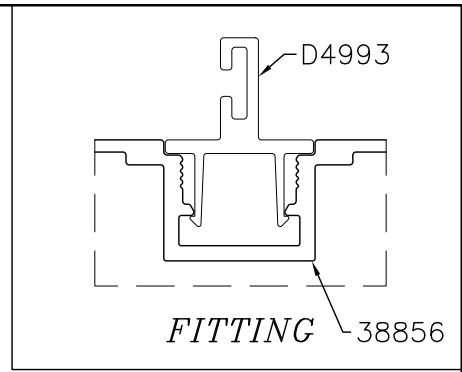
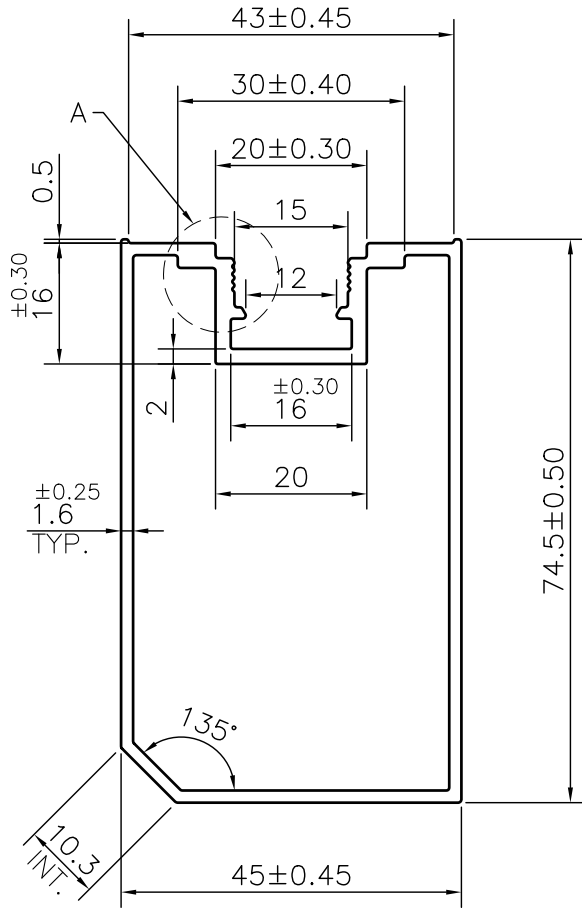

SYMBOL OF QUALITY
AN ISO 9001 COMPANY

JINDAL ALUMINIUM LTD.
BHIWADI-301019 (INDIA)

	NAME	DATE
DRAWN	ASHUTOSH	04-10-2023
CHECKED		
APPROVED		
SCALE		1:1
AREA mm ²		448.89
PERIMETER mm.		268.958
WEIGHT kg/m		1.212
DRAWING No.	SECTION No.	
IAL-D-4990	-	
38856	38856	

1. ALL DIMENSIONS ARE IN mm.
2. ROUND OFF ALL SHARP CORNERS WITH 0.40 mm.
3. TOLERANCES WILL BE AS PER BS:EN-755-9, UNLESS OTHERWISE SPECIFIED

PARTY'S NAME	HARMONY SYSTEM	
PARTY'S DRAWING No.	AS PER DRAWING	
ALLOY & TEMPER	6063 T6	PRODUCT CODE:-055
		HSN CODE:- 76042100
DESCRIPTION	CURTAIN WALL SECTION	