

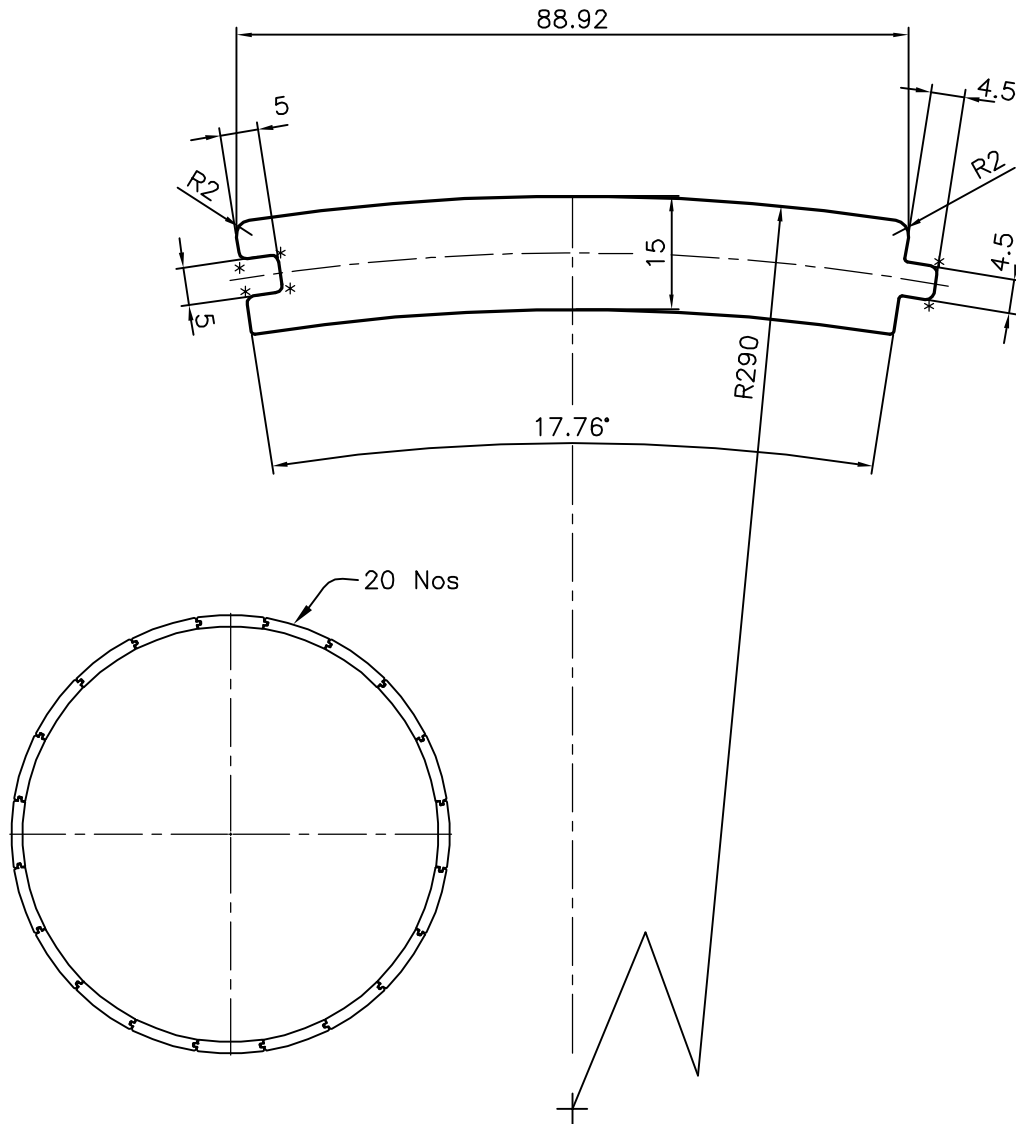

P-14770-1

S4520

40502



* = 1.0 RADIUS (6 PLACES)

 SYMBOL OF QUALITY AN ISO 9001 COMPANY	JINDAL ALUMINIUM LTD. BANGALORE-560073 (INDIA)	NAME	DATE
		DRAWN	J.P.KAUSHIK 18-06-2015
		CHECKED	
		APPROVED	S.S.GARG 09-07-2015
1. ALL DIMENSIONS ARE IN mm. 2. ROUND OFF ALL SHARP CORNERS WITH 0.40 mm. 3. TOLERANCES WILL BE AS PER IS:3965-1981 UNLESS OTHERWISE SPECIFIED		SCALE	1:1
		AREA mm ²	1305.973
		PERIMETER mm.	219.06
PARTY'S NAME	BAJAJ TAMBULA PINNED PRODUCTS PVT. LTD, KOLKATA	WEIGHT kg/m	3.526
PARTY'S DRAWING No.	BT/LR/022/15-16 AS PER AutoCAD DRAWING	DRAWING No.	SECTION No.
ALLOY & TEMPER	6082 T6	S4520	S4520
		40502	40502
DESCRIPTION	INTERLOCK TYPE SECTION		