

P-14668-1

S4480

40505

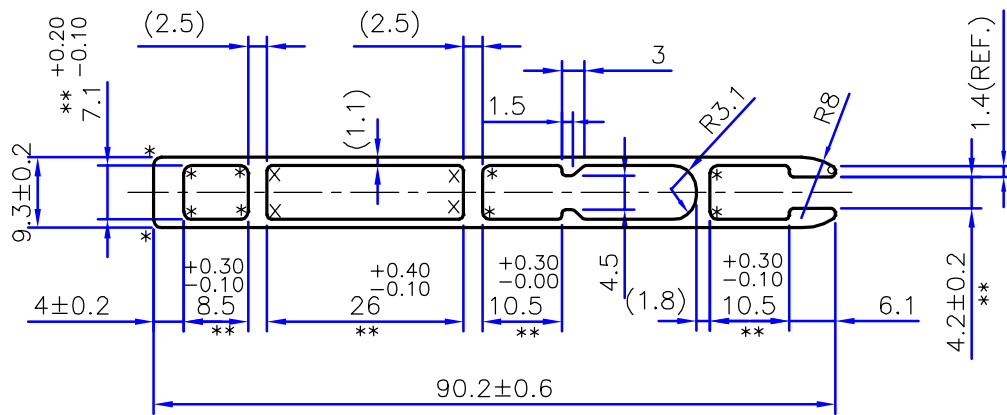

** = IMPORTANT DIMENSIONS

FLATNESS = ±0.76 mm ON 90.2 mm WIDTH

UNSPECIFIED RADIUS 0.5 mm

x = 0.60 RADIUS (4 PLACES)
* = 1.0 RADIUS (10 PLACES)

 SYMBOL OF QUALITY AN ISO 9002 COMPANY	JINDAL ALUMINIUM LTD. BANGALORE-560073 (INDIA)	NAME	DATE
		DRAWN	J.P.KAUSHIK
		CHECKED	
		APPROVED	S.S.GARG
			01-06-2015
1. ALL DIMENSIONS ARE IN mm. 2. ROUND OFF ALL SHARP CORNERS WITH 0.40 mm. 3. TOLERANCES WILL BE AS PER IS:6477-1983 UNLESS OTHERWISE SPECIFIED		SCALE	1:1
		AREA mm ²	300.275
		PERIMETER mm.	232.701
		WEIGHT kg/m	0.811
PARTY'S NAME	BHARAT HEALD FRAME WORKS, BHIWANDI	DRAWING No.	SECTION No.
PARTY'S DRAWING No.	MODIFIED OF SECTION No:-27665 & REQUIREMENT	P-14668-1	-
ALLOY & TEMPER	HE9 WP	S4480	S4480
		40505	40505
DESCRIPTION	TEXTILE SECTION		