

P-18286

41505

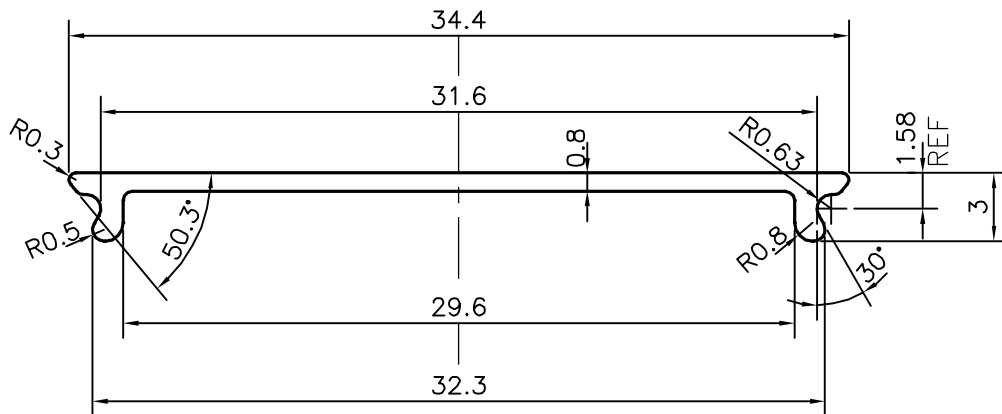

1:1

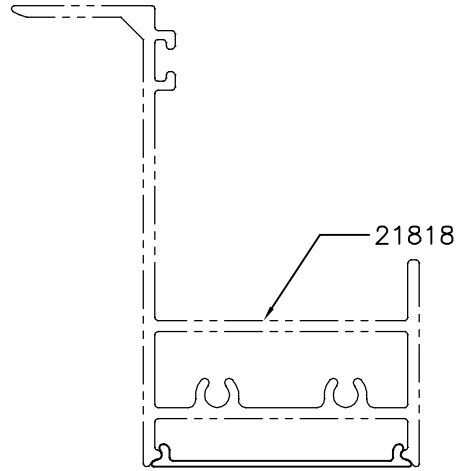

TOLERANCE CHART CD = CIRCUMSCRIBING CIRCLE

CD ≤ 100	100 < CD ≤ 200	200 < CD < 300	300 < CD < 500
UPTO 10mm - ±0.25	±0.30	±0.35	±0.40
10.0 - 25.0 - ±0.30	±0.40	±0.50	±0.60
25.0 - 50.0 - ±0.50	±0.60	±0.80	±0.90
50.0 - 100.0 - ±0.70	±0.90	±1.10	±1.30
100 - 150 - -	±1.10	±1.30	±1.50
150 - 200 - -	±1.3	±1.50	±1.80
200 - 300 - -	-	±1.70	±2.10
300 - 450 - -	-	-	±2.80



SYMBOL OF QUALITY
AN ISO 9001 COMPANY

JINDAL ALUMINIUM LTD.
BANGALORE-560073 (INDIA)

	NAME	DATE
DRAWN	J.P.KAUSHIK	02-06-2018
CHECKED		
APPROVED	B.NATARAJA	30-08-2018

1. ALL DIMENSIONS ARE IN mm.
2. ROUND OFF ALL SHARP CORNERS WITH 0.40 mm.
3. TOLERANCES WILL BE AS PER BS:EN-755-9, UNLESS OTHERWISE SPECIFIED

SCALE	3:1
AREA mm ²	32.563
PERIMETER mm.	77.153
WEIGHT kg/m	0.088

PARTY'S NAME	PRAYOSHA ENTERPRISES LTD., UGANDA	DRAWING No.	P-18286	SECTION No.	-
PARTY'S DRAWING No.	AS PER DRAWING		41505		41505
ALLOY & TEMPER	6063 T6				
DESCRIPTION	CLIP SECTION				