

P-16211-1
X2061
41512

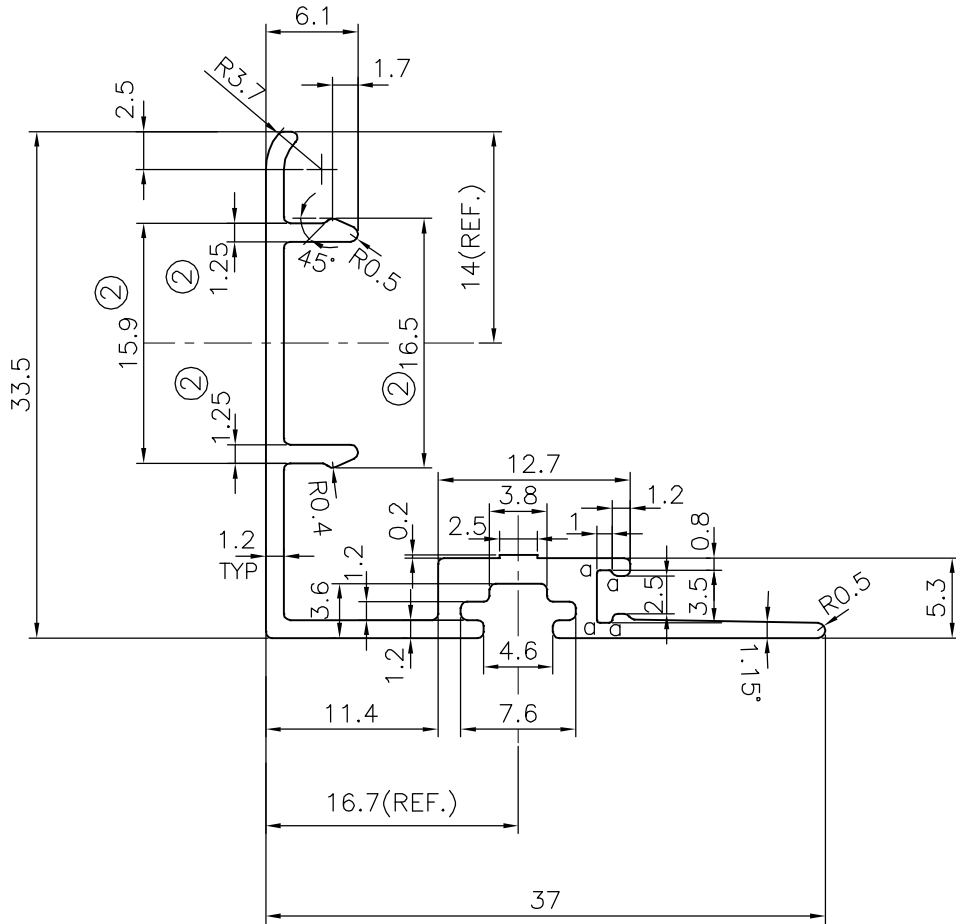
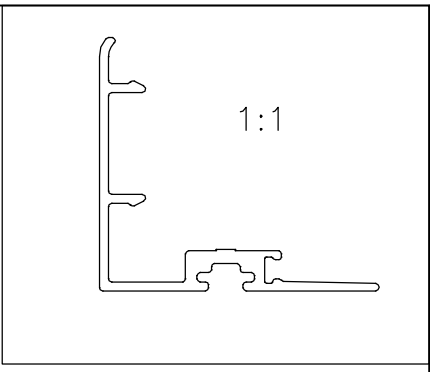

ISSUE-2

DIMENSION CHANGED FROM 17.0 mm TO 16.50 mm & 16 mm TO 15.9 mm
THICKNESS CHANGED FROM 1.30 mm TO 1.25 mm

WEIGHT ALSO CHANGED FROM 0.330 TO 0.327 kg/m

α = RADIUS 0.20 (4 PLACES)

 SYMBOL OF QUALITY AN ISO 9001 COMPANY	JINDAL ALUMINIUM LTD. BANGALORE-560073 (INDIA)	NAME	DATE
		DRAWN	J.P.KAUSHIK
		CHECKED	
		APPROVED	B.NATARAJA
		SCALE	2:1
		AREA mm ²	121.292
		PERIMETER mm.	182.746
		WEIGHT kg/m	0.327
PARTY'S NAME	HATIM GLAZING & CLADDING PVT. LTD., MUMBAI	DRAWING No.	SECTION No.
PARTY'S DRAWING No.	AS PER AutoCAD DRAWING	P-16211-1	-
ALLOY & TEMPER	6063 T6	X2061	X2061(ISSUE-2)
DESCRIPTION	GLAZING CLIP SECTION	41512	41512