

P-17611-1

S5602

41516

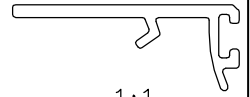

1:1

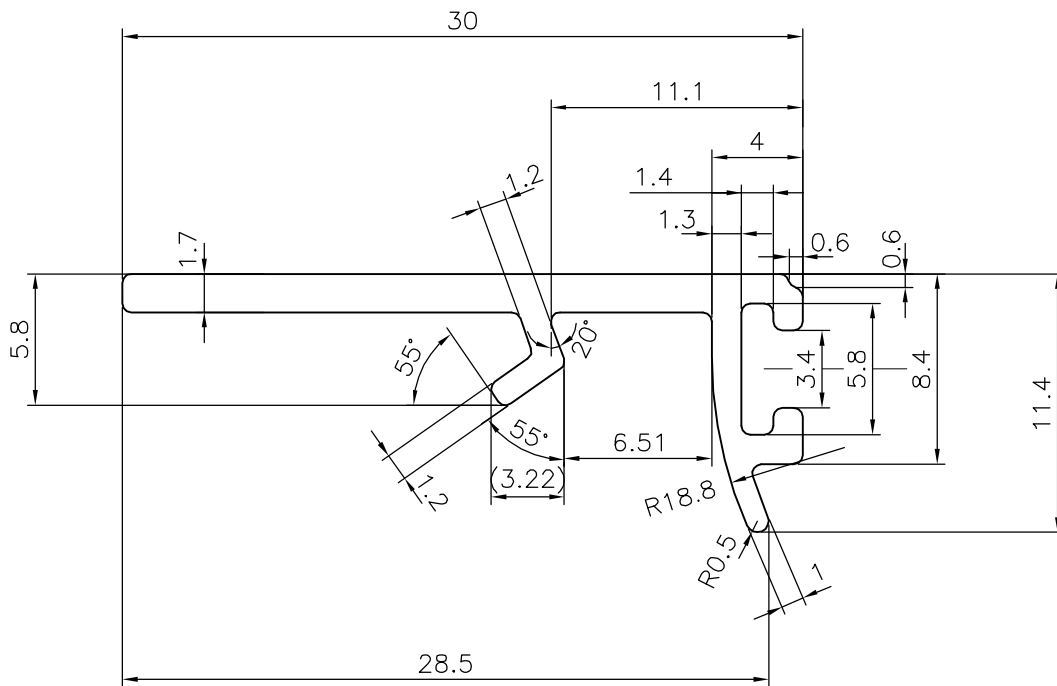
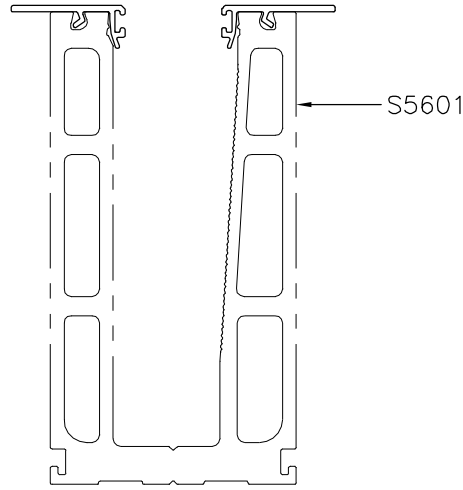

SYMBOL OF QUALITY
AN ISO 9001 COMPANY

JINDAL ALUMINIUM LTD.
BANGALORE-560073 (INDIA)

	NAME	DATE
DRAWN	J.P.KAUSHIK	18-11-2017
CHECKED		
APPROVED	B.NATARAJA	29-11-2017
SCALE		3:1
AREA mm ²		73.127
PERIMETER mm.		98.658
WEIGHT kg/m		0.197
DRAWING No.		SECTION No.
P-17611-1		-
S5602		S5602
41516		41516

1. ALL DIMENSIONS ARE IN mm. 2. ROUND OFF ALL SHARP CORNERS WITH 0.4 mm. 3. TOLERANCES WILL BE AS PER IS:3965-1981 , UNLESS OTHERWISE SPECIFIED	
PARTY'S NAME	PANCHSHIL INFRASTRUCTURE HOLDINGS PVT. LTD., PUNE
PARTY'S DRAWING No.	AS PER AutoCAD DRAWING
ALLOY & TEMPER	6063 T6
DESCRIPTION	CLIP SECTION