

P-17729-1

S5627

41528

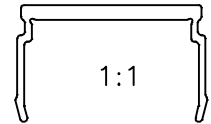

1:1

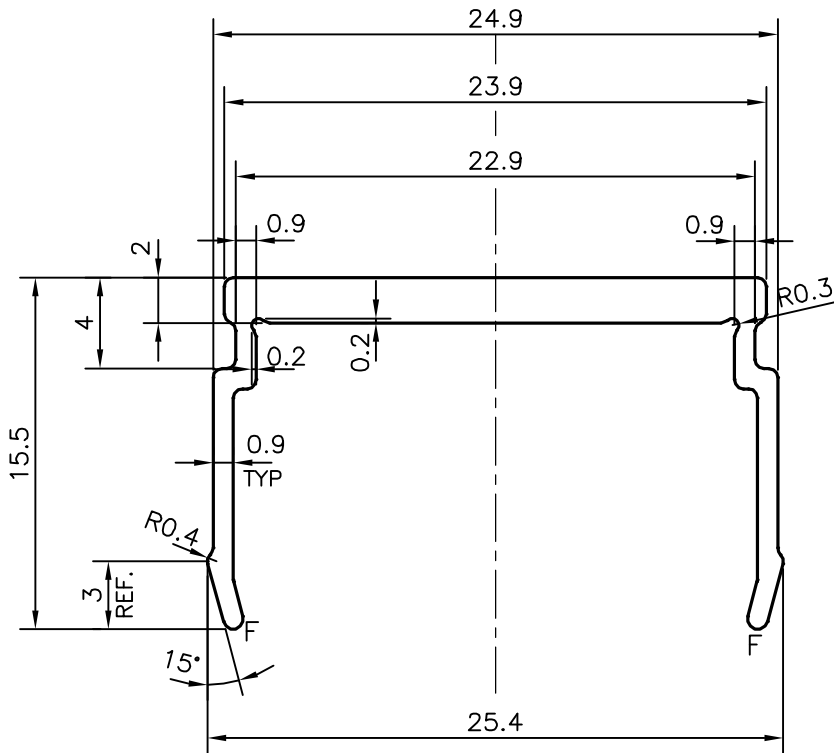

F = FULL RADIUS (2 PLACES)



SYMBOL OF QUALITY
AN ISO 9001 COMPANY

JINDAL ALUMINIUM LTD.
BANGALORE-560073 (INDIA)

	NAME	DATE
DRAWN	J.P.KAUSHIK	22-12-2017
CHECKED		
APPROVED	B.NATARAJA	26-12-2017
SCALE		3:1
AREA mm ²		73.829
PERIMETER mm.		107.91
WEIGHT kg/m		0.199
DRAWING No.	SECTION No.	
P-17729-1	-	
S5627	S5627	
41528	41528	

1. ALL DIMENSIONS ARE IN mm.
2. ROUND OFF ALL SHARP CORNERS WITH 0.40 mm.
3. TOLERANCES WILL BE AS PER,IS:3965-1981 UNLESS OTHERWISE SPECIFIED

PARTY'S NAME	FLOOR JINNI, BANGALORE
PARTY'S DRAWING No.	AS PER DRAWING
ALLOY & TEMPER	6063 T6
DESCRIPTION	CLIP SECTION