

P-21173-2

41533

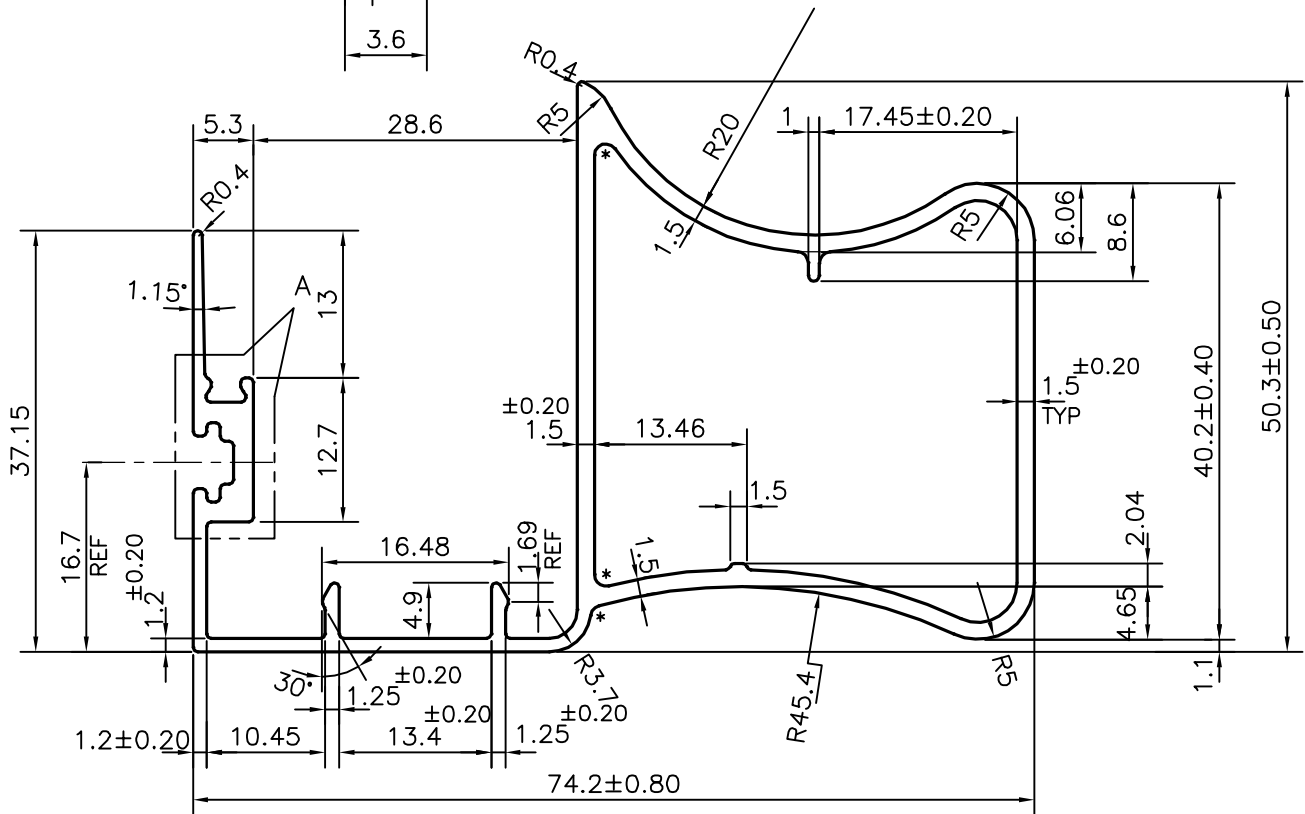
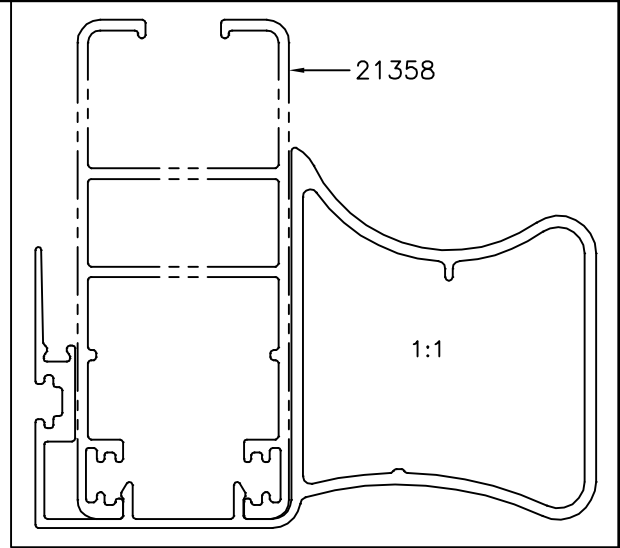
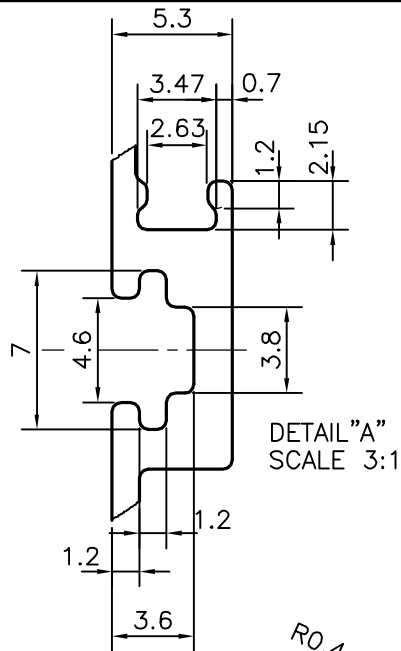

* = 1.0 RADIUS (3 PLACES)

TOLERANCES ON OVERALL DIMENSIONS OF HOLLOW SECTIONS

UPTO 20.0mm - ±0.30	UPTO 80.0mm - ±0.70	UPTO 180.0mm - ±1.27	1. STRAIGHTNESS=1.7mm/M 2. TWIST=1.7mm/M 3. ANGULARITY= ±2° 4. FLATNESS =0.006xWIDTH
UPTO 30.0mm - ±0.38	UPTO 100.0mm - ±0.80	UPTO 200.0mm - ±1.40	
UPTO 40.0mm - ±0.45	UPTO 120.0mm - ±0.90	UPTO 225.0mm - ±1.52	
UPTO 50.0mm - ±0.52	UPTO 140.0mm - ±1.00		
UPTO 60.0mm - ±0.60	UPTO 160.0mm - ±1.14		



SYMBOL OF QUALITY
AN ISO 9001 COMPANY

JINDAL ALUMINIUM LTD.
BANGALORE-560073 (INDIA)

	NAME	DATE
DRAWN	J.P.KAUSHIK	12-08-2020
CHECKED		
APPROVED	B.NATARAJA	21-08-2020

- ALL DIMENSIONS ARE IN mm.
- ROUND OFF ALL SHARP CORNERS WITH 0.40 mm.
- TOLERANCES WILL BE AS PER,IS:6477-1983 UNLESS OTHERWISE SPECIFIED

SCALE	1.5:1
AREA mm ²	374.889
PERIMETER mm.	353.698
WEIGHT kg/m	1.012

PARTY'S NAME	HATIM GLAZING & CLADDING PVT LTD., MUMBAI
PARTY'S DRAWING No.	AS PER DRAWING-HAT 11
ALLOY & TEMPER	6063 T6
DESCRIPTION	GLAZING CLIP SECTION

DRAWING No.	SECTION No.
P-21173-2	-
41533	41533