

P-18226-2  
X2351  
41538

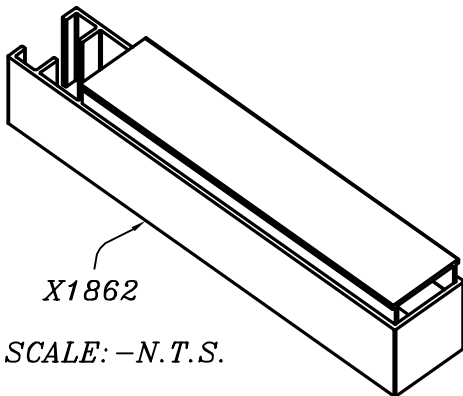

SCALE: - 1:1

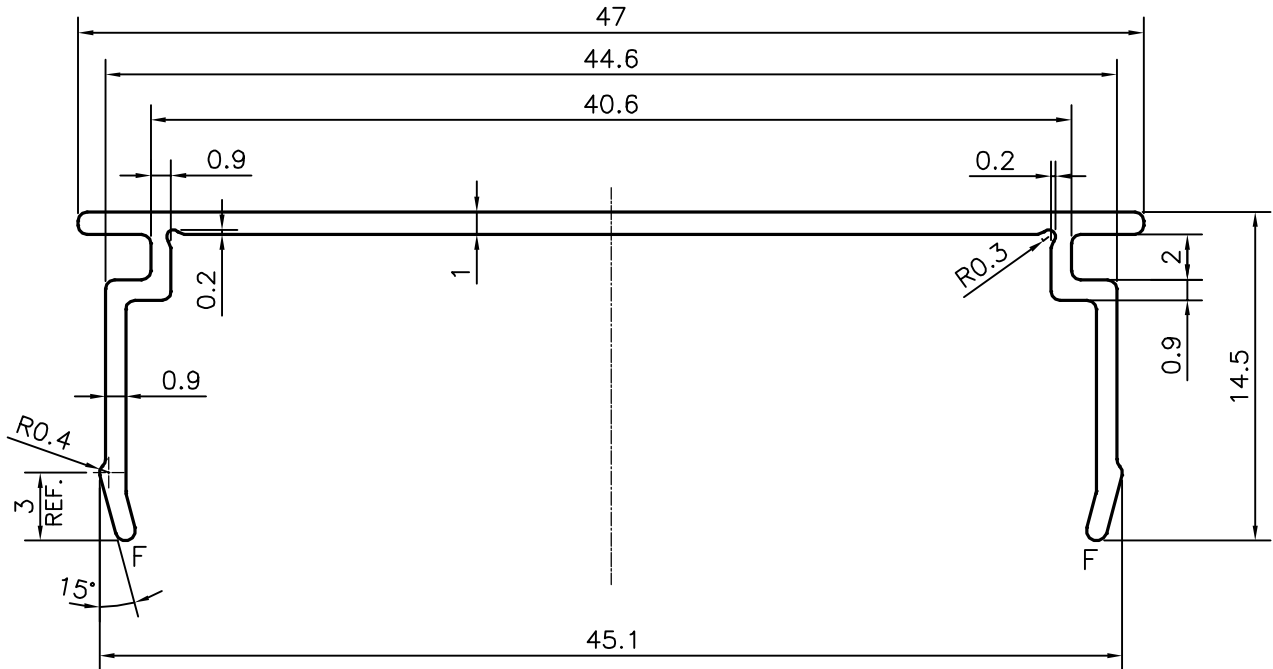

☞ PROFILE MATCHING WITH SECTION No. X1862

F = FULL RADIUS (2 PLACES)

 SYMBOL OF QUALITY AN ISO 9001 COMPANY	<b>JINDAL ALUMINIUM LTD.</b> BANGALORE-560073 (INDIA)		NAME	DATE
		DRAWN	PARVESH	14-06-2018
		CHECKED		
		APPROVED	B.NATARAJA	25-06-2018
		SCALE	3:1	
		AREA mm <sup>2</sup>	74.859	
		PERIMETER mm.	156.008	
		WEIGHT kg/m	0.202	
PARTY'S NAME	FLOOR JINNI, BANGALORE	DRAWING No.	SECTION No.	
PARTY'S DRAWING No.	AS PER DRAWING	P-18226-2	-	
ALLOY & TEMPER	6063 T6	X2351	X2351	
DESCRIPTION	CLIP SECTION	41538	41538	