

P-21641

42501

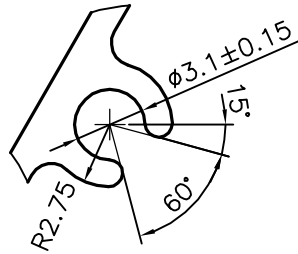

DETAIL OF "A"
SCALE 3:1

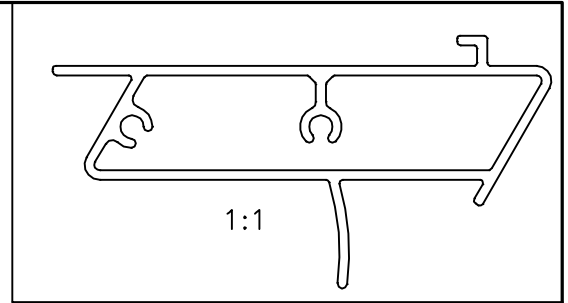

1:1

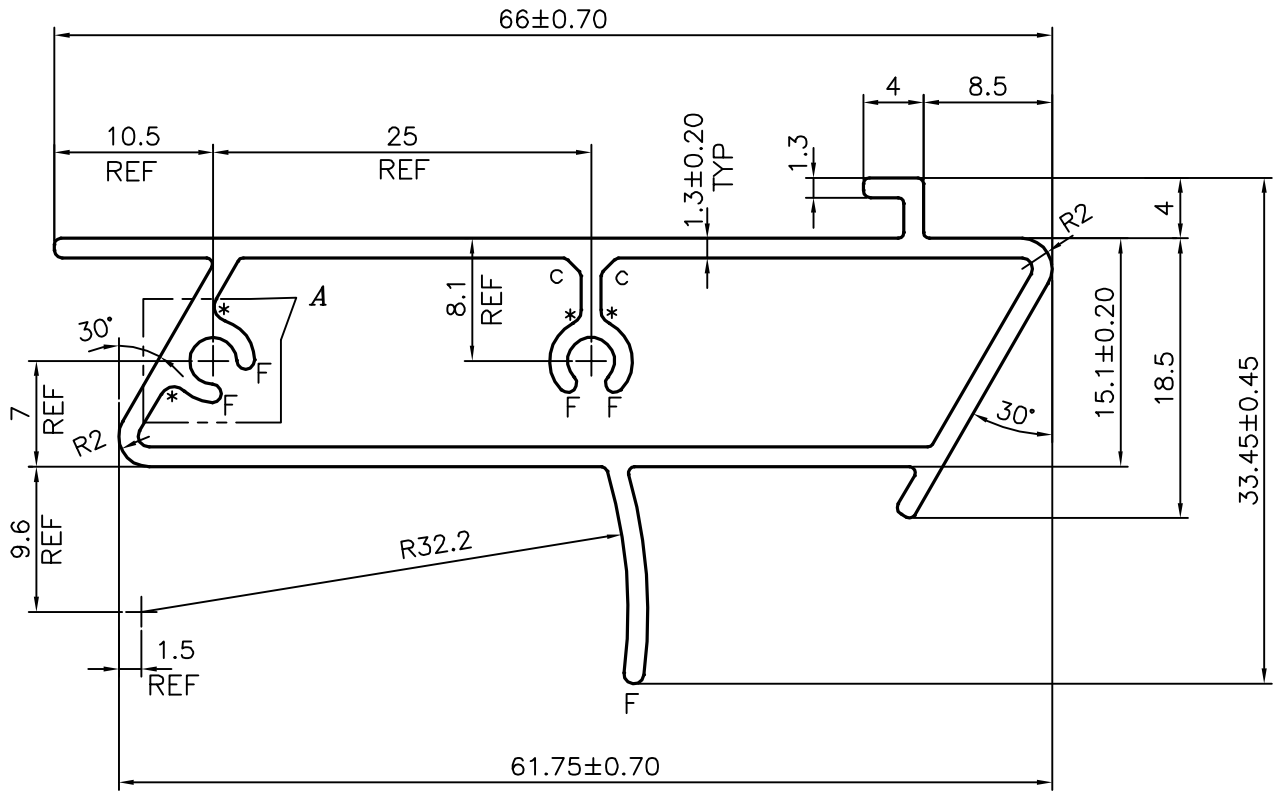

AVERAGE WEIGHT:-0.622 kg/m TO 0.762 kg/m

C = CHAMFER 1.0x45° (2 PLACES)

* = 1.0 RADIUS (4 PLACES)

F = FULL RADIUS (5 PLACES)



SYMBOL OF QUALITY
AN ISO 9001 COMPANY

JINDAL ALUMINIUM LTD.
BANGALORE-560073 (INDIA)

	NAME	DATE
DRAWN	J.P.KAUSHIK	08-10-2020
CHECKED		
APPROVED	B.NATARAJA	24-10-2020

1. ALL DIMENSIONS ARE IN mm.
2. ROUND OFF ALL SHARP CORNERS WITH 0.40 mm.
3. TOLERANCES WILL BE AS PER IS:6477-1983 , UNLESS OTHERWISE SPECIFIED

SCALE	2:1
AREA mm ²	256.463
PERIMETER mm.	209.049
WEIGHT kg/m	0.692

PARTY'S NAME	STELLAR GASTRONOM PVT. LTD., GHAZIABAD	DRAWING No.	SECTION No.
PARTY'S DRAWING No.	AS PER DRAWING	P-21641	-
ALLOY & TEMPER	6063 T6	42501	42501
DESCRIPTION	MISC. SECTION		