

P-21642

42502

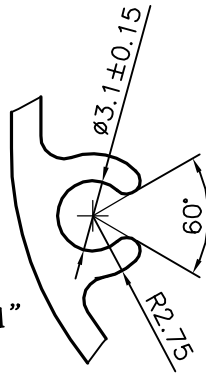

DETAIL OF "A"
SCALE 3:1

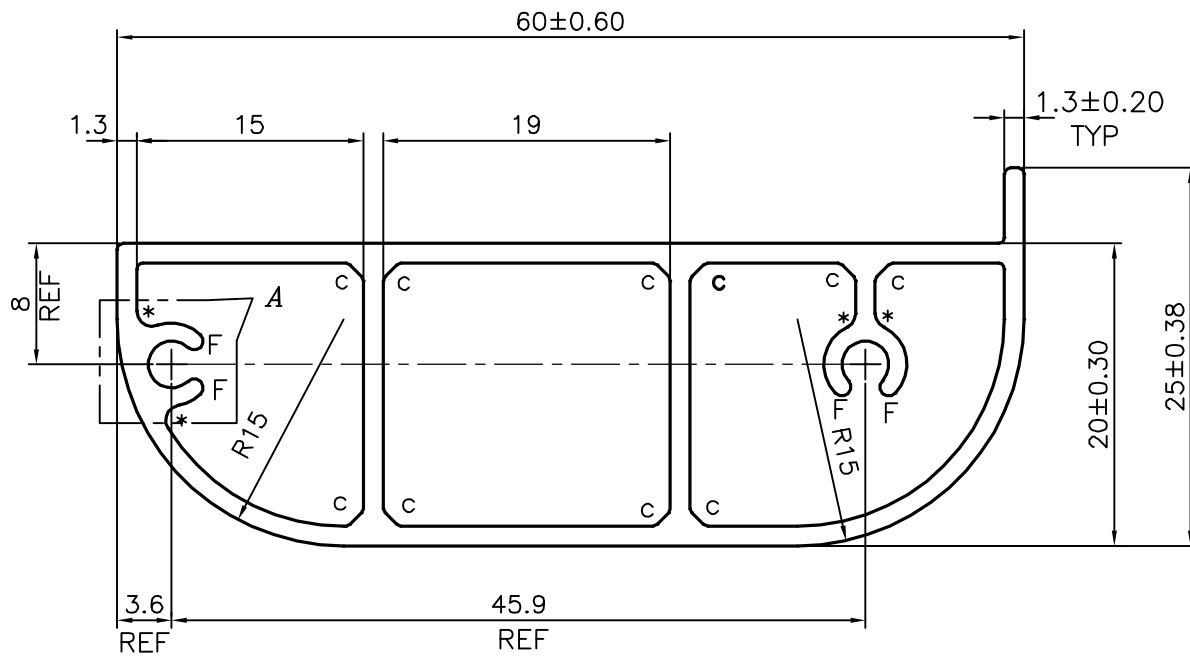
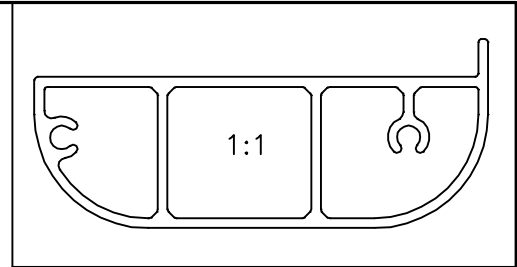

C = CHAMFER 1.0x45° (10 PLACES)

* = 1.0 RADIUS (4 PLACES)

F = FULL RADIUS (4 PLACES)

AVERAGE WEIGHT: -0.662 kg/m TO 0.810 kg/m



SYMBOL OF QUALITY
AN ISO 9001 COMPANY

JINDAL ALUMINIUM LTD.
BANGALORE-560073 (INDIA)

	NAME	DATE
DRAWN	J.P.KAUSHIK	08-10-2020
CHECKED		
APPROVED	B.NATARAJA	24-10-2020
SCALE		2:1
AREA mm ²		272.57
PERIMETER mm.		156.437
WEIGHT kg/m		0.736
DRAWING No.	SECTION No.	
P-21642	-	
42502	42502	

1. ALL DIMENSIONS ARE IN mm.
2. ROUND OFF ALL SHARP CORNERS WITH 0.40 mm.
3. TOLERANCES WILL BE AS PER IS:6477-1983 , UNLESS OTHERWISE SPECIFIED

PARTY'S NAME	STELLAR GASTRONOM PVT. LTD., GHAZIABAD
PARTY'S DRAWING No.	AS PER DRAWING
ALLOY & TEMPER	6063 T6
DESCRIPTION	MISC. SECTION