

P-21763

42504

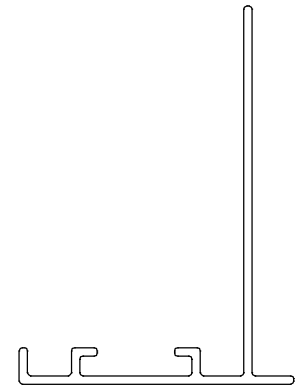
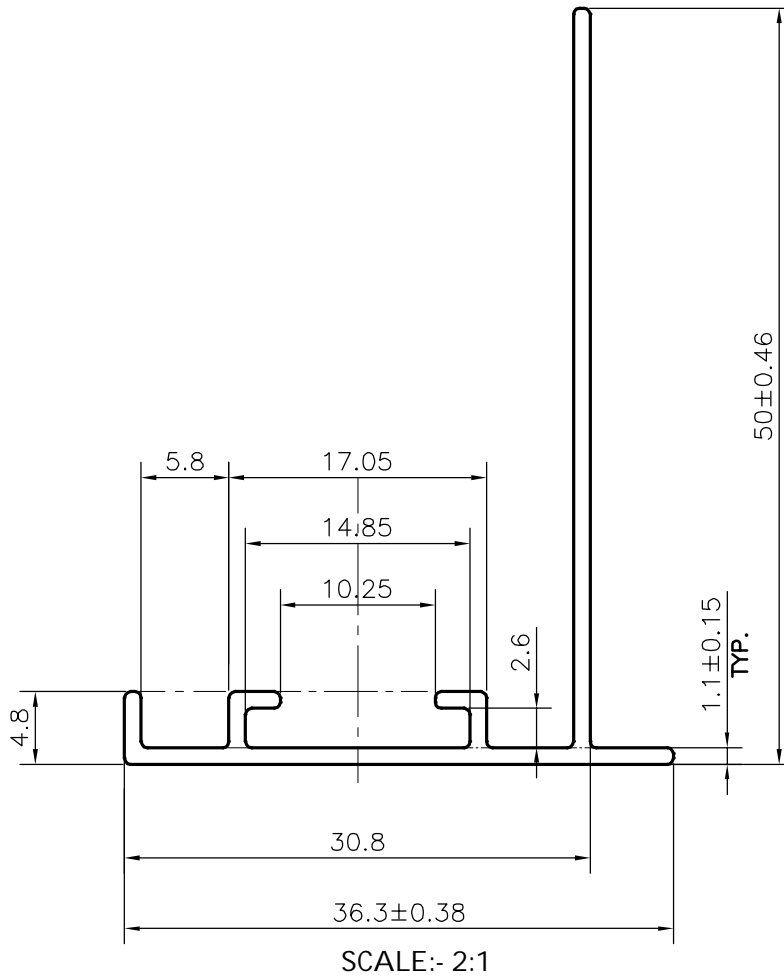

SCALE:- 1:1

APPROXIMATE WEIGHT RANGE - 0.245 - 0.353 kg/m

TOLERANCES ON OVERALL WIDTHS & WIDTHS ACROSS FLATS OF BARS, & REGULAR SECTIONS

UPTO 6.40mm - ± 0.20
 UPTO 10.0mm - ± 0.23
 UPTO 12.0mm - ± 0.25
 UPTO 16.0mm - ± 0.28
 UPTO 25.0mm - ± 0.30

UPTO 32.0mm - ± 0.38
 UPTO 50.0mm - ± 0.46
 UPTO 60.0mm - ± 0.53
 UPTO 80.0mm - ± 0.69
 UPTO 100.0mm - ± 0.75

UPTO 120.0mm - ± 0.85
 UPTO 160.0mm - ± 1.02
 UPTO 200.0mm - ± 1.14
 UPTO 250.0mm - ± 1.40
 UPTO 300.0mm - ± 1.65

1. STRAIGHTNESS=1.7mm/M
 2. TWIST=1.7mm/M
 3. ANGULARITY= $\pm 2^\circ$
 4. FLATNESS = $0.007 \times \text{WIDTH}$



SYMBOL OF QUALITY
 AN ISO 9001 COMPANY

JINDAL ALUMINIUM LTD.
 BANGALORE-560073 (INDIA)

	NAME	DATE
DRAWN	DARPAN	07-11-2020

CHECKED		
APPROVED	B.NATARAJA	26/11/2020

SCALE	2:1
-------	-----

AREA mm ²	110.853
----------------------	---------

PERIMETER mm.	200.223
---------------	---------

WEIGHT kg/m	0.299
-------------	-------

DRAWING No.	SECTION No.
P-21763	-
42504	42504

- ALL DIMENSIONS ARE IN mm.
- ROUND OFF ALL SHARP CORNERS WITH 0.40 mm.
- TOLERANCES WILL BE AS PER **IS:3965-1981**, UNLESS OTHERWISE SPECIFIED

PARTY'S NAME	BENGAL INDUSTRIES PVT. LTD., FARIDABAD
--------------	--

PARTY'S DRAWING No.	AS PER SAMPLE & REQUIREMENT
---------------------	-----------------------------

ALLOY & TEMPER	6063 T6
----------------	---------

DESCRIPTION	AIR GRILL SECTION
-------------	-------------------