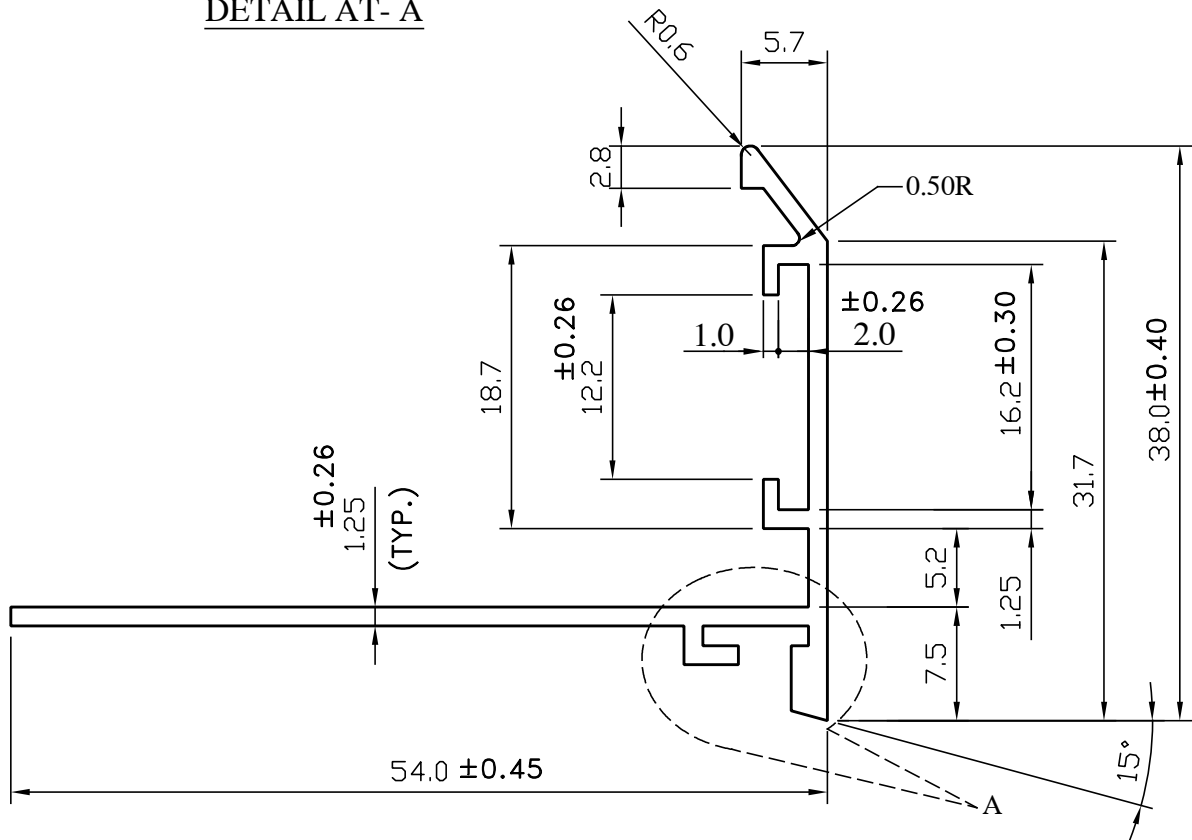
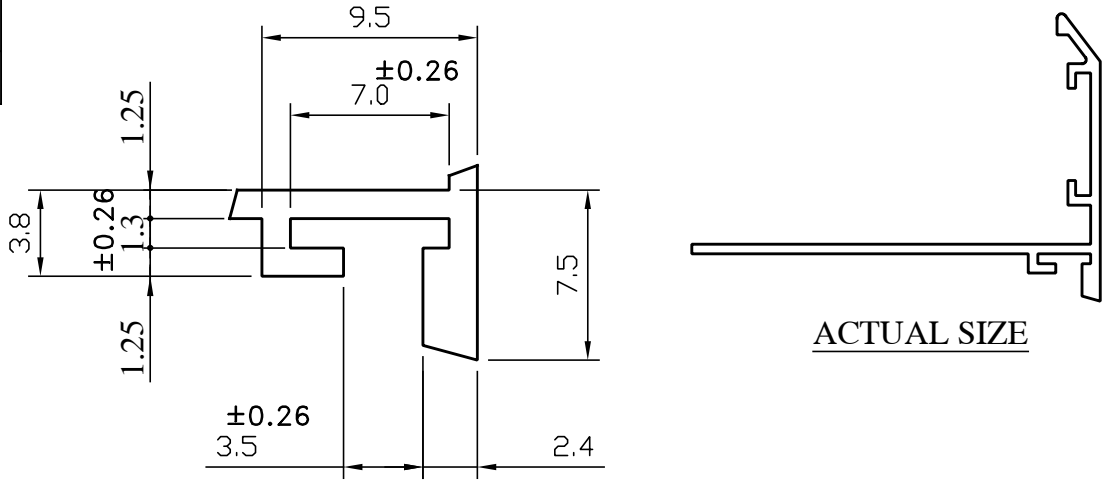

IAL-D-4442

42532

TWIST = $1/4^\circ/300$ M.M.

FLATNESS = WIDTH X 0.005mm.

STRAIGHTNESS = 1.50 mm./mtr.

ANGULARITY = $\pm 1.5^\circ$ 

SYMBOL OF QUALITY
AN ISO 9001 COMPANY

JINDAL ALUMINIUM LTD.
BANGALORE-560073 (INDIA)

	NAME	DATE
DRAWN	S.K.SHARMA	08-03-2022
CHECKED		
APPROVED		

1. ALL DIMENSIONS ARE IN mm.
2. ROUND OFF ALL SHARP CORNERS WITH 0.40 mm.
3. TOLERANCES WILL BE AS PER BS:EN-755-9 , UNLESS OTHERWISE SPECIFIED

SCALE	1:1&2:1
AREA mm ²	139.5
PERIMETER mm.	218.0
WEIGHT kg/m	0.377

PARTY'S NAME	M/S. RAVISTAR
PARTY'S DRAWING No.	AS PER DRAWING
ALLOY & TEMPER	6063-T6
DESCRIPTION	AIR GRILL SECTION

DRAWING No.	SECTION No.
IAL-D-4442	-
42532	42532