

IAL-D-4440

42534

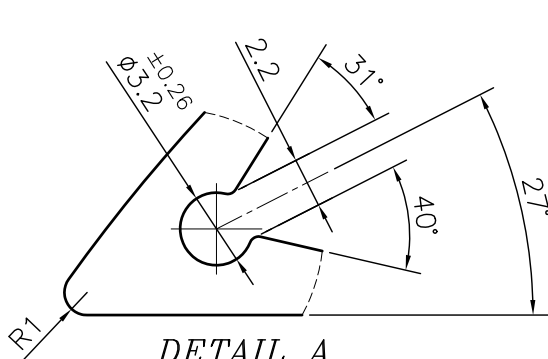

DETAIL A
SCALE 3:1

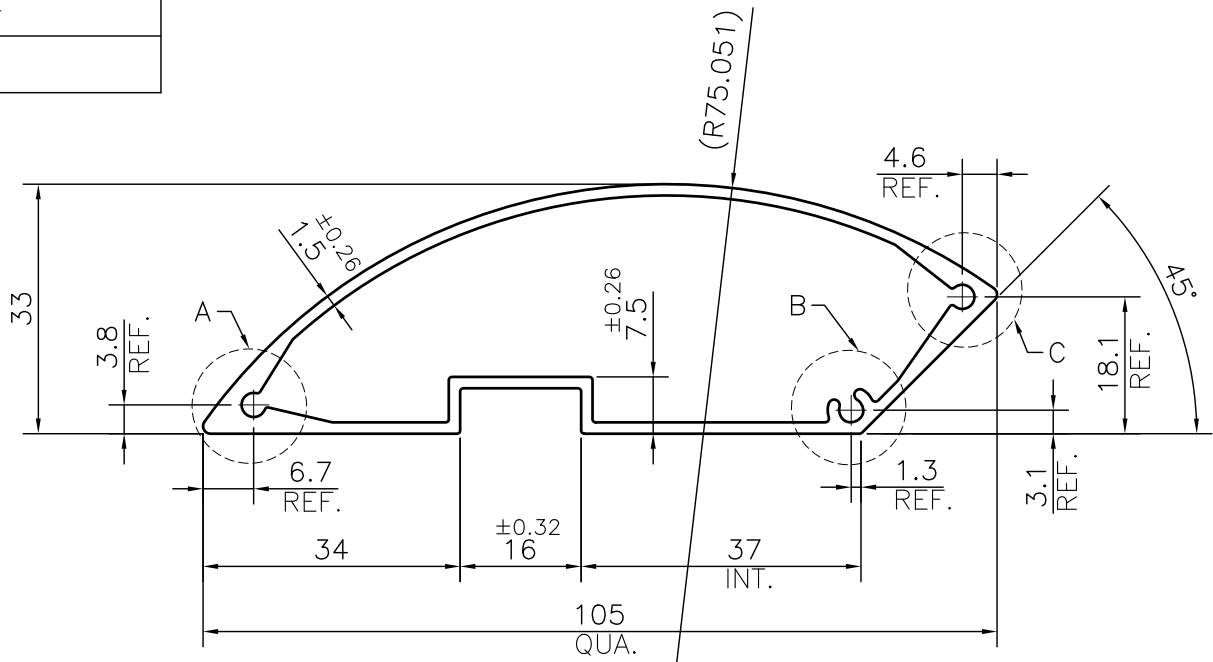
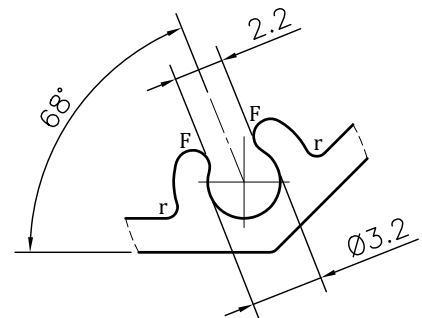

DETAIL B
SCALE 3:1

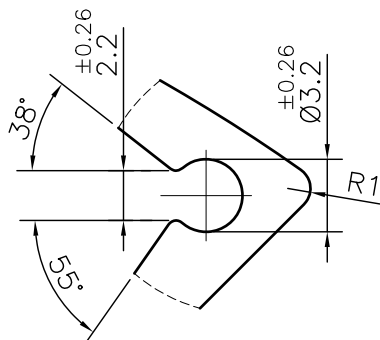

DETAIL C
SCALE 3:1

NOTE:-

r= 0.50 RADIUS (2 PLACES)
F= FULL RADIUS (2 PLACES)

1. STRAIGHTNESS= 1.7mm/M
2. TWIST= 1.7mm/M
3. ANGULARITY= $\pm 2^\circ$
4. FLATNESS= 0.007xWIDTH



SYMBOL OF QUALITY
AN ISO 9001 COMPANY

JINDAL ALUMINIUM LTD.
BHIWADI-301019 (INDIA)

	NAME	DATE
DRAWN	ASHUTOSH	27-09-2023
CHECKED		
APPROVED		
SCALE		1:1
AREA mm ²		423.195
PERIMETER mm.		243.784
WEIGHT kg/m		1.143
DRAWING No.	SECTION No.	
IAL-D-4440	-	
42534	42534	

1. ALL DIMENSIONS ARE IN mm.
2. ROUND OFF ALL SHARP CORNERS WITH 0.40 mm.
3. TOLERANCES WILL BE AS PER BS:EN-755-9 , UNLESS OTHERWISE SPECIFIED

PARTY'S NAME	RAVISTAR	
PARTY'S DRAWING No.	AS PER DRAWING	
ALLOY & TEMPER	6063 T6	PRODUCT CODE:-082
		HSN CODE:- 76042100
DESCRIPTION	AIR GRILL SECTION	