

IA-D-5547

43613

CODE:-RABP473-1E

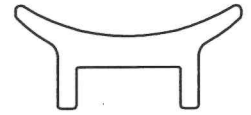

SCALE:- 1:1

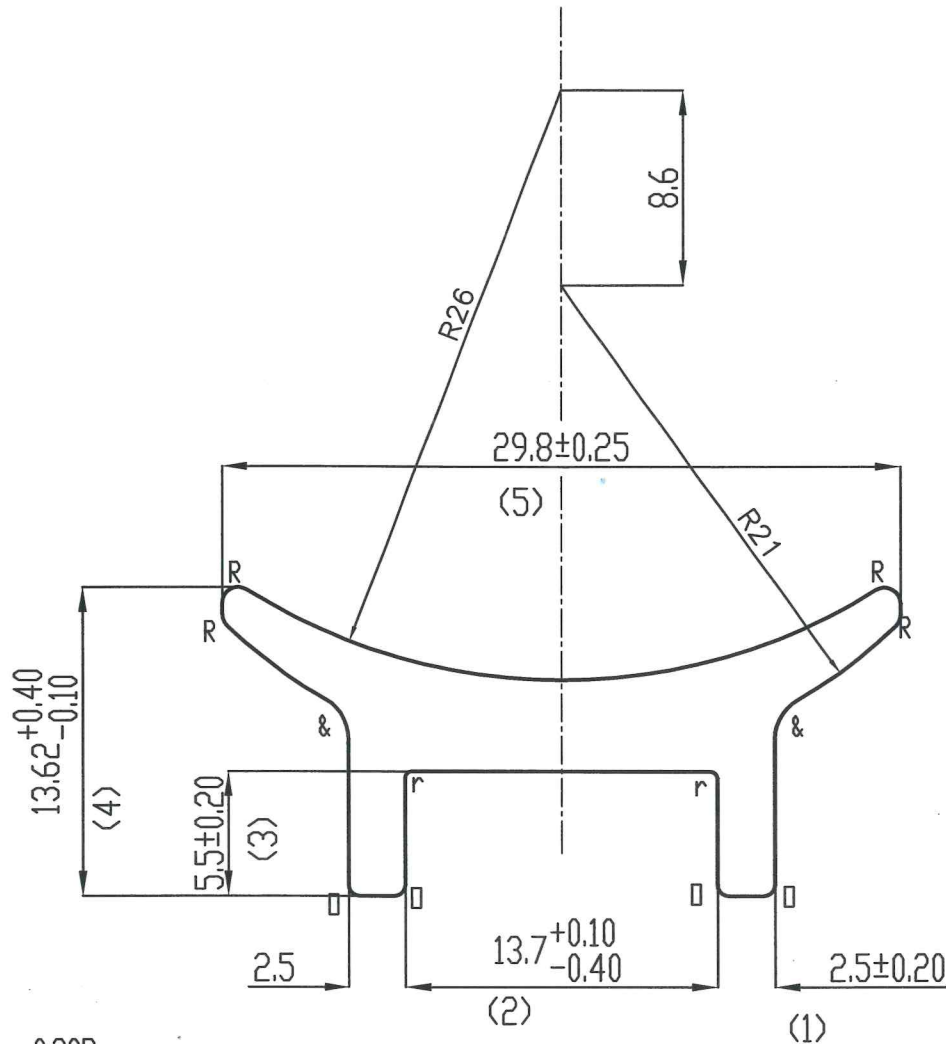

NOTE:-

$$r = 0.30R$$

$$\square = 0.50R$$

$$R = 0.70R$$

$$\& = 2.00R$$

NOTE:-

1. THERE SHOULD NOT BE BURRS , SCRATCHES AND FLASHES
2. HARDNESS :- 95 - 115 HB
3. LENGTH :- 3100mm.

TWIST=±1/4°/300 mm./M.
STRAIGHTNESS= 1.50 mm./MTR.
ANGULARITY=±1.5°

CONTROLLED COPY



SYMBOL OF QUALITY
AN ISO 9001 COMPANY

JINDAL ALUMINIUM LTD.
BANGALORE-560073 (INDIA)

1. ALL DIMENSIONS ARE IN mm.
2. ROUND OFF ALL SHARP CORNERS WITH 0.40 mm.
3. TOLERANCES WILL BE AS PER BS:EN-755-9 , UNLESS OTHERWISE SPECIFIED

	NAME	DATE
DRAWN	PARVESH	07-12-2021
CHECKED	<i>Red</i>	07/12/21
APPROVED	<i>B</i>	8/12/21
SCALE		1:3
AREA mm ²		143.097
PERIMETER mm.		91.769
WEIGHT kg/m		0.386
DRAWING No.		SECTION No.
IA-D-5547		-
43613		43613

PARTY'S NAME ENSTO INDIA PVT. LTD.

PARTY'S DRAWING No. AS PER DRAWING

ALLOY & TEMPER 6082-T6

DESCRIPTION INDUSTRIAL SECTION