

IA-D-5548

43614

CADE ; -RABP472



SCALE: - 1:1

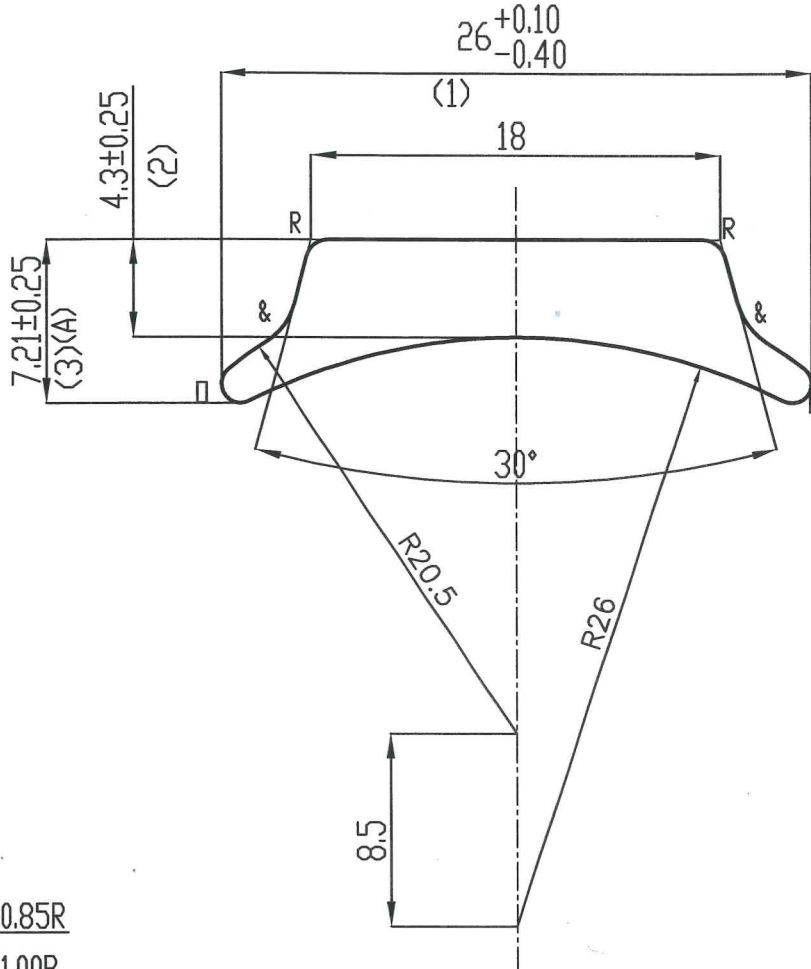

NOTE:-

$\square = 0.85R$

$R = 1.00R$

$\& = 3.00R$

CONTROLLED COPY

NOTE:-

1. THERE SHOULD NOT BE BURRS , SCRATCHES AND FLASHES
2. HARDNESS :- 95 - 115 HB
3. LENGTH :- 3100mm.

TWIST=±1/4°/300 mm./M.
STRAIGHTNESS= 1.50 mm./MTR.
ANGULARITY=±1.5'



SYMBOL OF QUALITY
AN ISO 9001 COMPANY

JINDAL ALUMINIUM LTD.
BANGALORE-560073 (INDIA)

	NAME	DATE
DRAWN	PARVESH	07-12-2021
CHECKED	<i>Parv</i>	07/12/21
APPROVED	<i>Ⓟ</i>	07/12/21
SCALE		1:3
AREA mm ²		107.470
PERIMETER mm.		61.199
WEIGHT kg/m		0.292
DRAWING No.		SECTION No.
IA-D-5548		-
43614		43614

1. ALL DIMENSIONS ARE IN mm.
2. ROUND OFF ALL SHARP CORNERS WITH 0.40 mm.
3. TOLERANCES WILL BE AS PER BS:EN-755-9 , UNLESS OTHERWISE SPECIFIED

PARTY'S NAME	ENSTO INDIA PVT. LTD.
PARTY'S DRAWING No.	AS PER DRAWING
ALLOY & TEMPER	6082-T6
DESCRIPTION	INDUSTRIAL SECTION