

IAL-D-6194

43621

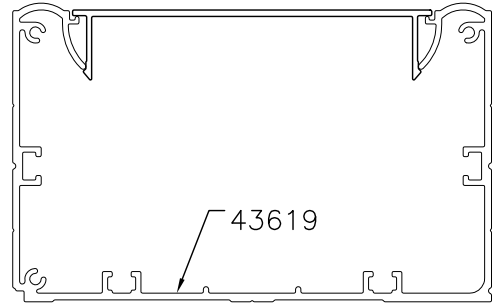

**MATCHING  
SCALE 1:2**

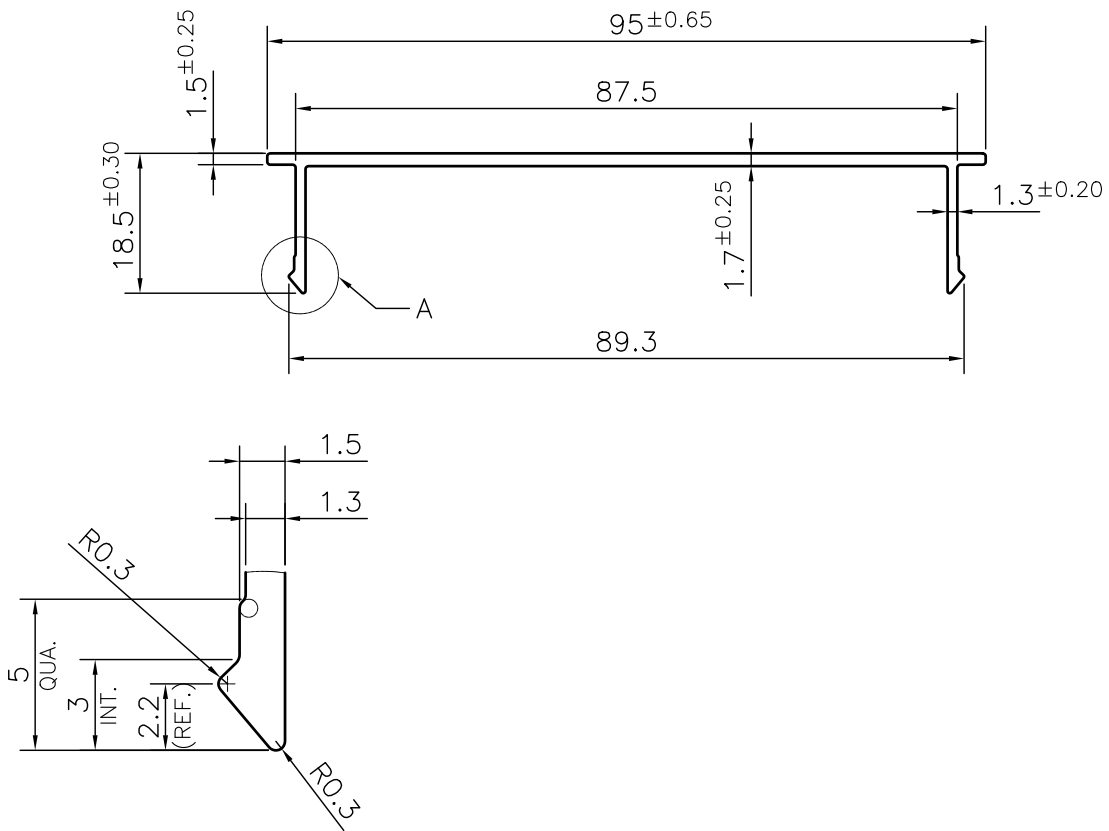

**DETAIL A  
SCALE 4:1**

1. STRAIGHTNESS= 1.7mm/M
2. TWIST= 1.7mm/M
3. ANGULARITY=  $\pm 2^\circ$
4. FLATNESS= 0.007xWIDTH



SYMBOL OF QUALITY  
AN ISO 9001 COMPANY

**JINDAL ALUMINIUM LTD.**  
**BHIWADI-301019 (INDIA)**

	NAME	DATE
DRAWN	ASHUTOSH	09-04-2024
CHECKED		
APPROVED		
SCALE		1:1
AREA mm <sup>2</sup>		205.655
PERIMETER mm.		259.13
WEIGHT kg/m		0.555
DRAWING No.	SECTION No.	
IAL-D-6194	-	
43621	43621	

1. ALL DIMENSIONS ARE IN mm.
2. ROUND OFF ALL SHARP CORNERS WITH 0.40 mm.
3. TOLERANCES WILL BE AS PER BS:EN-755-9 , UNLESS OTHERWISE SPECIFIED

PARTY'S NAME	MDD	
PARTY'S DRAWING No.	AS PER DRAWING	
ALLOY & TEMPER	6063 T6	PRODUCT CODE:-085
		HSN CODE:- 76042990
DESCRIPTION	MEDICAL SECTION	