

IAL-D-5102

43632

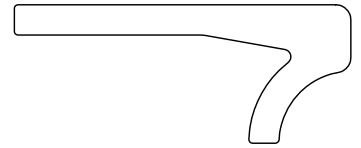

SCALE 1:1

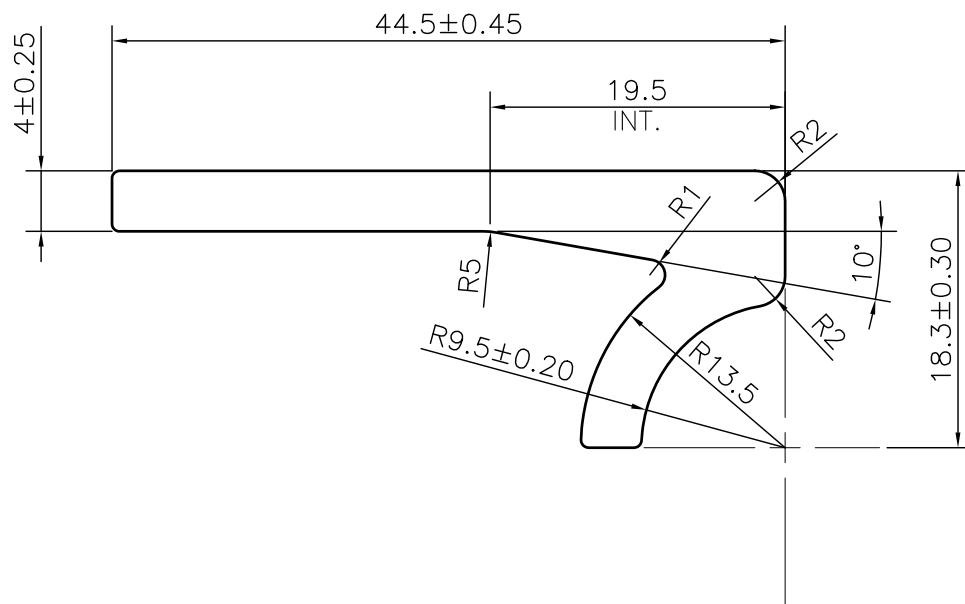

☞ ROUND OFF ALL SHARP CORNERS WITH 0.50 mm.

1. STRAIGHTNESS= 1.7mm/M
2. TWIST= 1.7mm/M
3. ANGULARITY= $\pm 2^\circ$
4. FLATNESS= 0.007xWIDTH



SYMBOL OF QUALITY
AN ISO 9001 COMPANY

JINDAL ALUMINIUM LTD.
BHIWADI-301019 (INDIA)

	NAME	DATE
DRAWN	ASHUTOSH	01-11-2023
CHECKED		
APPROVED		
SCALE		2:1
AREA mm ²		273.394
PERIMETER mm.		124.27
WEIGHT kg/m		0.738
DRAWING No.	SECTION No.	
IAL-D-5102	-	
43632	43632	

1. ALL DIMENSIONS ARE IN mm.
2. ROUND OFF ALL SHARP CORNERS WITH 0.40 mm.
3. TOLERANCES WILL BE AS PER BS:EN-755-9, UNLESS OTHERWISE SPECIFIED

PARTY'S NAME	PRANAV VIKAS	
PARTY'S DRAWING No.	AS PER DRAWING	
ALLOY & TEMPER	6063 T6	PRODUCT CODE:-085
		HSN CODE:- 76042990
DESCRIPTION	AUTOMOBILE SECTION	