

IAL-D-4730

46078

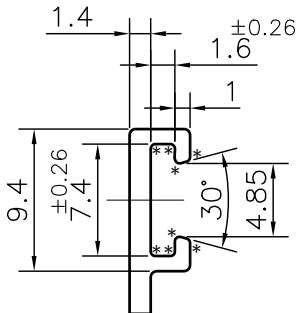

DETAIL A  
SCALE 2:1

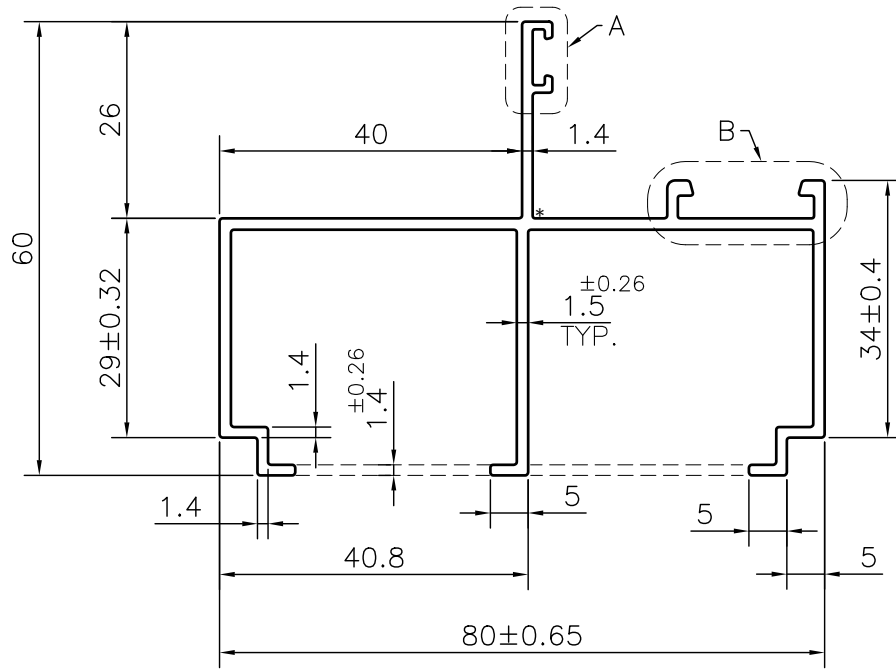
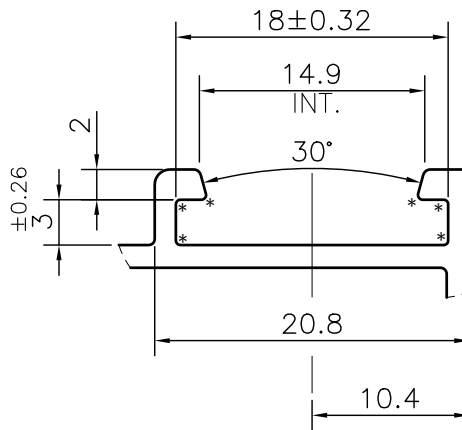

DETAIL B  
SCALE 2:1

**NOTE:-**

**\*= 0.30 RADIUS (14 PLACES)**

1. STRAIGHTNESS= 1.7mm/M
2. TWIST= 1.7mm/M
3. ANGULARITY= ±2°
4. FLATNESS= 0.007xWIDTH



SYMBOL OF QUALITY  
AN ISO 9001 COMPANY

**JINDAL ALUMINIUM LTD.**  
BHIWADI-301019 (INDIA)

	NAME	DATE
DRAWN	ASHUTOSH	21-09-2023
CHECKED		
APPROVED		
SCALE		1:1
AREA mm <sup>2</sup>		358.892
PERIMETER mm.		485.44
WEIGHT kg/m		0.969
DRAWING No.	SECTION No.	
IAL-D-4730	-	
46078	46078	

1. ALL DIMENSIONS ARE IN mm.
2. ROUND OFF ALL SHARP CORNERS WITH 0.40 mm.
3. TOLERANCES WILL BE AS PER BS:EN-755-9 , UNLESS OTHERWISE SPECIFIED

PARTY'S NAME	AAP DIVISION	
PARTY'S DRAWING No.	AS PER DRAWING	
ALLOY & TEMPER	6063 T6	PRODUCT CODE:-048
		HSN CODE:- 76042990
DESCRIPTION	WINDOW SECTION	