

IAL-D-3725

46097

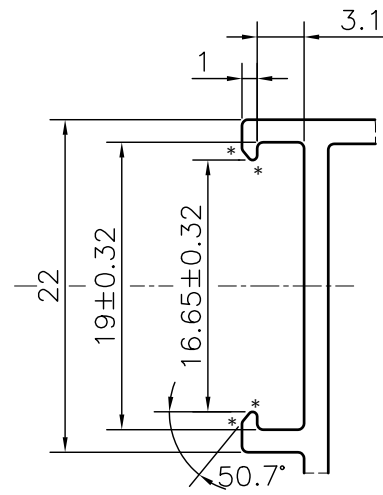

DETAIL A
SCALE 2:1

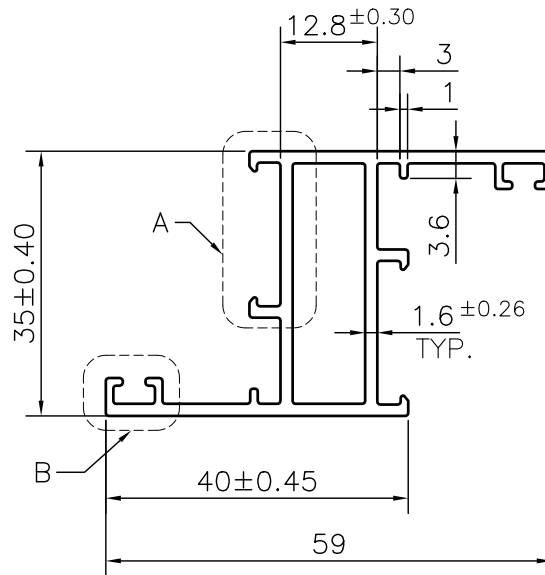

DETAIL B
SCALE 2:1

NOTE:-

*= 0.30 RADIUS (4 PLACES)

1. STRAIGHTNESS= 1.7mm/M
2. TWIST= 1.7mm/M
3. ANGULARITY= ±2°
4. FLATNESS= 0.007xWIDTH



SYMBOL OF QUALITY
AN ISO 9001 COMPANY

JINDAL ALUMINIUM LTD.
BHIWADI-301019 (INDIA)

	NAME	DATE
DRAWN	ASHUTOSH	13-02-2024
CHECKED		
APPROVED		

1. ALL DIMENSIONS ARE IN mm.
2. ROUND OFF ALL SHARP CORNERS WITH 0.40 mm.
3. TOLERANCES WILL BE AS PER BS:EN-755-9 , UNLESS OTHERWISE SPECIFIED

PARTY'S NAME	AAP DIVISION
--------------	--------------

PARTY'S DRAWING No.	AS PER DRAWING
---------------------	----------------

ALLOY & TEMPER	6063 T6	PRODUCT CODE:-048
		HSN CODE:- 76042100

DESCRIPTION	WINDOW SECTION
-------------	----------------

SCALE	1:1
-------	-----

AREA mm ²	267.961
----------------------	---------

PERIMETER mm.	265.101
---------------	---------

WEIGHT kg/m	0.723
-------------	-------

DRAWING No.	SECTION No.
-------------	-------------

IAL-D-3725	-
------------	---

46097	46097
-------	-------