

IAL-D-3726

46098

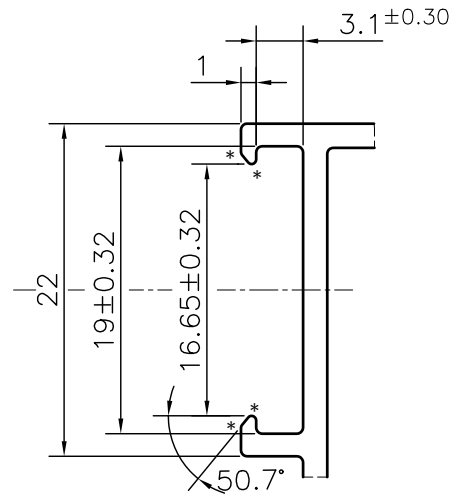

DETAIL A
SCALE 2:1

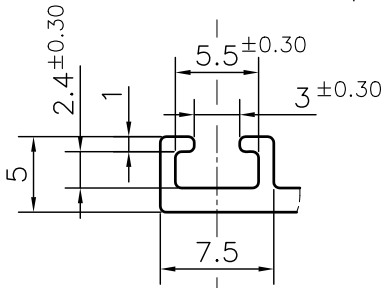
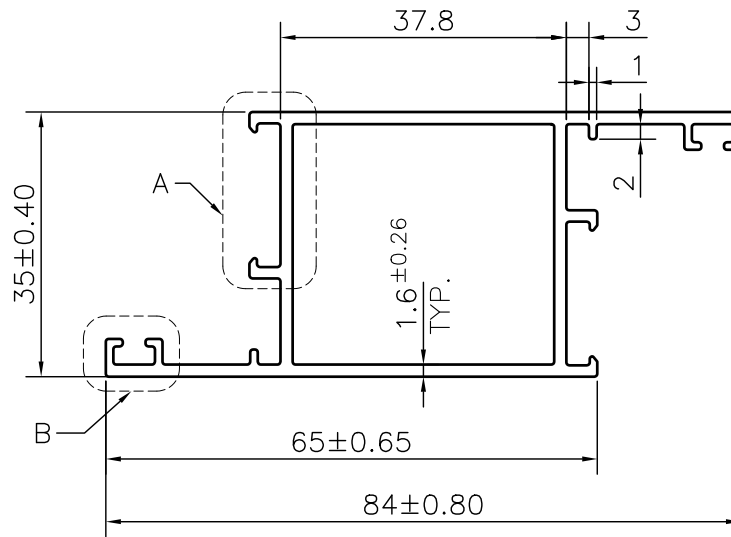

DETAIL B
SCALE 2:1

NOTE:-

*= 0.30 RADIUS (4 PLACES)

1. STRAIGHTNESS= 1.7mm/M
2. TWIST= 1.7mm/M
3. ANGULARITY= $\pm 2^\circ$
4. FLATNESS= 0.007xWIDTH



SYMBOL OF QUALITY
AN ISO 9001 COMPANY

JINDAL ALUMINIUM LTD.
BHIWADI-301019 (INDIA)

| | NAME | DATE |
|----------------------|-------------|------------|
| DRAWN | ASHUTOSH | 13-02-2024 |
| CHECKED | | |
| APPROVED | | |
| SCALE | | 1:1 |
| AREA mm ² | | 347.961 |
| PERIMETER mm. | | 315.101 |
| WEIGHT kg/m | | 0.939 |
| DRAWING No. | SECTION No. | |
| IAL-D-3726 | - | |
| 46098 | 46098 | |

1. ALL DIMENSIONS ARE IN mm.
2. ROUND OFF ALL SHARP CORNERS WITH 0.40 mm.
3. TOLERANCES WILL BE AS PER BS:EN-755-9, UNLESS OTHERWISE SPECIFIED

| | | |
|---------------------|----------------|--|
| PARTY'S NAME | AAP DIVISION | |
| PARTY'S DRAWING No. | AS PER DRAWING | |
| ALLOY & TEMPER | 6063 T6 | PRODUCT CODE:-048 HSN CODE:- 76042100 |
| DESCRIPTION | WINDOW SECTION | |