

MAL NO.-13063

A1019

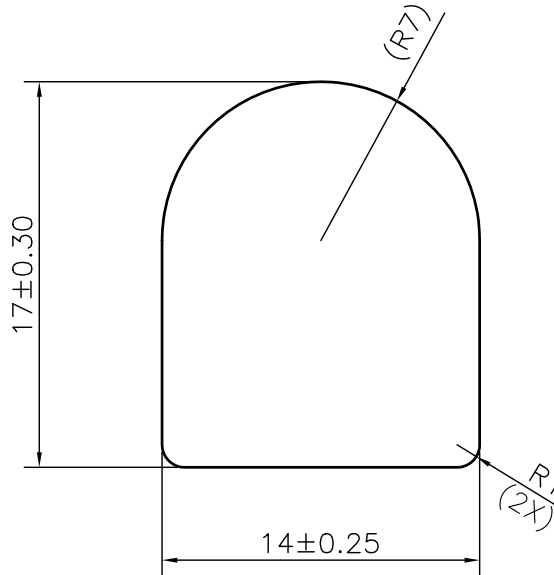

SCALE 1:1



- 1. STRAIGHTNESS= 1.7mm/M
- 2. TWIST= 1.7mm/M
- 3. ANGULARITY= ±2°
- 4. FLATNESS= 0.007xWIDTH



SYMBOL OF QUALITY
AN ISO 9001 COMPANY

JINDAL ALUMINIUM LTD.
BHIWADI-301019 (INDIA)

	NAME	DATE
DRAWN	ASHUTOSH	13-04-2024
CHECKED		
APPROVED		
SCALE		3:1
AREA mm ²		216.54
PERIMETER mm.		55.13
WEIGHT kg/m		0.585
DRAWING No.		SECTION No.
MAL NO.-13063		-
A1019		A1019

- 1. ALL DIMENSIONS ARE IN mm.
- 2. ROUND OFF ALL SHARP CORNERS WITH 0.40 mm.
- 3. TOLERANCES WILL BE AS PER BS:EN-755-9 , UNLESS OTHERWISE SPECIFIED

PARTY'S NAME	PRANAV VIKAS (I) LTD.	
PARTY'S DRAWING No.	AS PER DRAWING- RME7P1C01	
ALLOY & TEMPER	6063 T6	PRODUCT CODE:-005
		HSN CODE:- 76042990
DESCRIPTION	MISC. BAR	