

ACTUAL SIZE

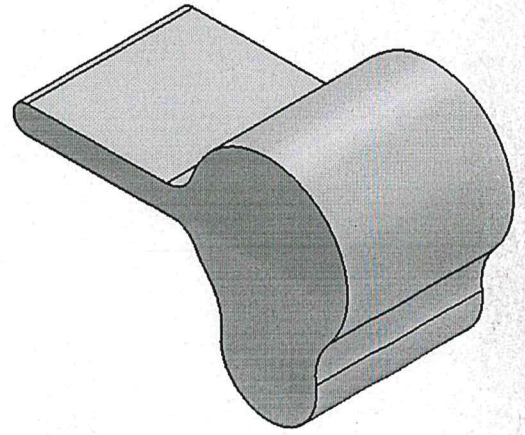

LENGTH = 2000 ± 10 mm

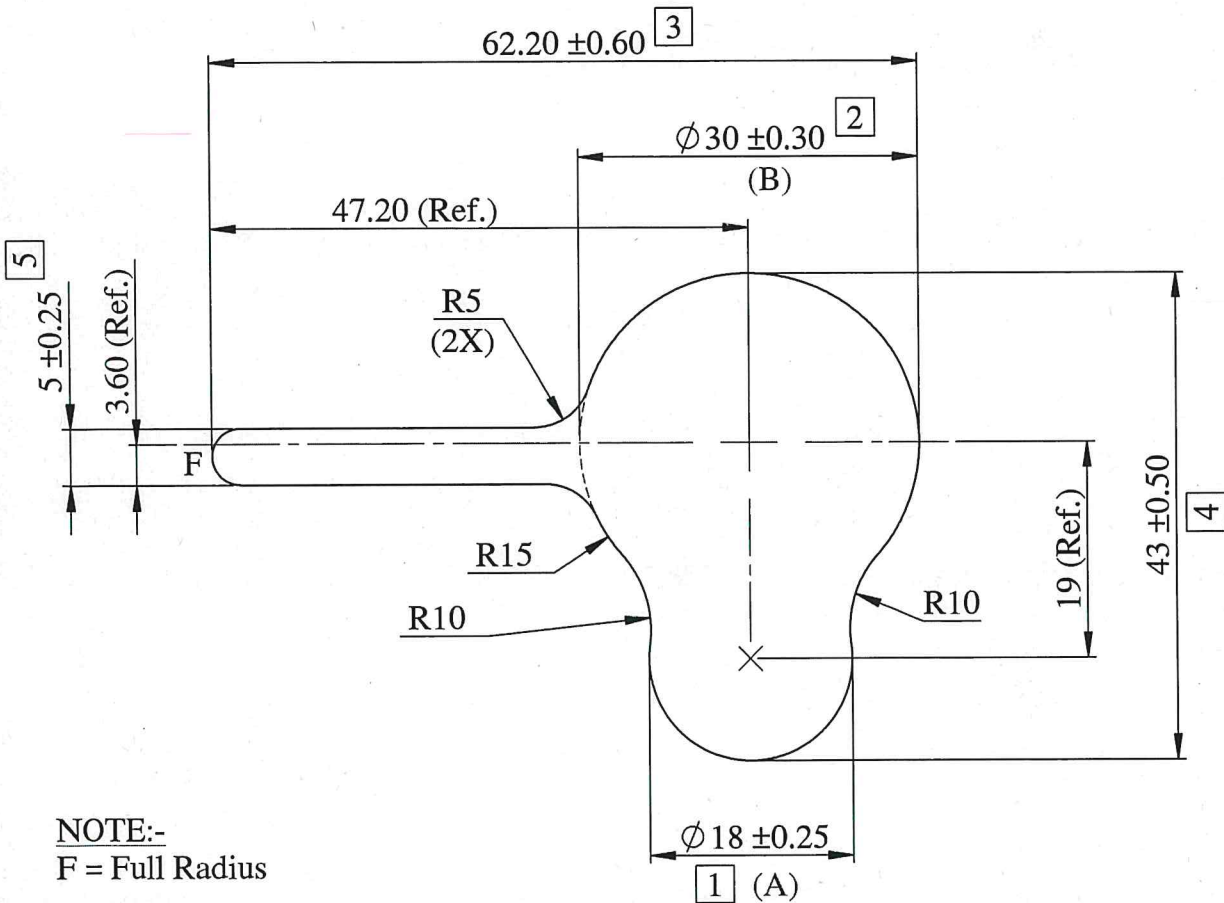

NOTE:-
F = Full Radius

TOLERANCE ON CUT LENGTH = +5 mm

PLEASE SPECIFY THE EXPOSED SURFACE

LOCATION:-P1-HOLE
ALL DIMENSION ARE IN mm.
UNSPECIFIED CORNER RADIUS:0.40

TOL. AS PER BS EN 755-9:2008
UNLESS SPECIFIED

TWIST = ±1/4°/300 M.M.
FLATNESS = WIDTH X 0.005mm.
STRAIGHTNESS = 1.50 M.M./MTR.
ANGULARITY = ±1.5°

INDO ALUSYS INDUSTRIES LIMITED BHIWADI RAJASTHAN - 301019

PARTY SAMPLE & DRG. RMGEN000225		PARTY NAME M/S PRANAV VIKAS			REF:- AS PER EMAIL DT.- 05.02.18			
			DRAWN	VIVEK YADAV	07.02.18	AREA	1089.35 MM ²	
			CHECKED	<i>[Signature]</i>		WEIGHT	2.941 KG/M.	
001	(B)	TOL. +/-0.30 WAS +/-0.40	APPROVED	<i>[Signature]</i>	20/2/18	WT. RANGE	----- Kg/12'	
	(A)	TOL. +/-0.25 WAS +/-0.30	SCALE	3:2	DATE	ALLOY	6005-T5	
	(REF.)	AS PER EMAIL DT.- 07.02.18	CRITICAL DIM.	*		MAL NO	16902	
REV. STATUS	REV. NO.	DESCRIPTION	SIGN DATE	PERIMETER	INT.	SEC.NO.	A-1056	
A4		REVISION			EXT.			