

B-523

Wt. Range:- 3.200 TO 3.500 KG/12'

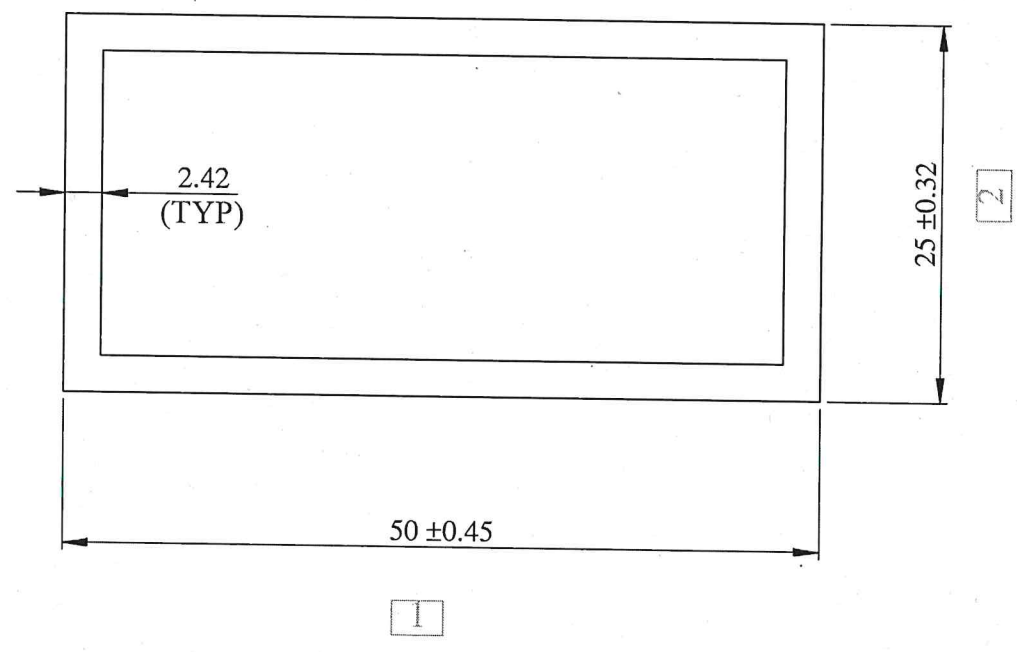
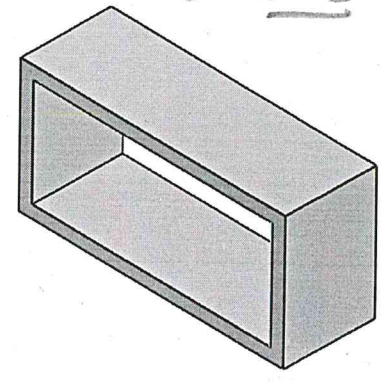

DIE NO. B-524

LOCATION:-P1-2hole  
 ALL DIMENSION ARE IN mm.  
 UNSPECIFIED CORNER RADIUS:0.40

**PLEASE SPECIFY THE EXPOSED SURFACE**  
 TOL. AS PER BS EN 755-9:2008  
 UNLESS SPECIFIED

TWIST = ±1/4°/300 M.M.  
 FLATNESS = WIDTH X 0.005mm.  
 STRAIGHTNESS = 1.50 M.M./MTR.  
 ANGULARITY = ±1.5°

**INDO ALUSYS INDUSTRIES LIMITED BHIWADI RAJASTHAN - 301019**

PARTY SAMPLE & DRG.		Ref.= B-524		PARTY NAME M/S S.M.			REF:- AS PER LATTER Dt.- 21.10.16		
				DRAWN	VIVEK YADAV	22.10.16	AREA	339.57	MM <sup>2</sup>
				CHECKED	<i>[Signature]</i>	11/01/17	WEIGHT	0.917	KG/M.
				APPROVED	<i>[Signature]</i>		WT. RANGE	-----	Kg/12'
				SCALE	2:1	DATE	ALLOY	6063-T6	
00	(REF.)	CRITICAL DIM. *					MAL NO	15794	
REV. STATUS	REV. NO.	DESCRIPTION	SIGN DATE	PERIMETER	INT.	130.64	SEC.NO.	B-1059	
A4		REVISION			EXT.	150.0			