

P-JAL-B-029
-
B-1814

NOTE:-
R= 2.00R

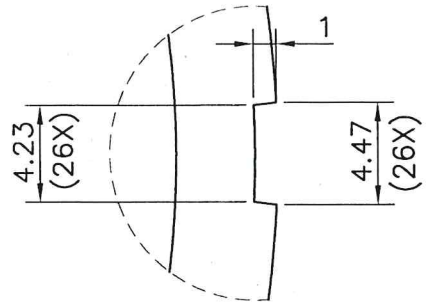

DETAIL A
SCALE 3:1

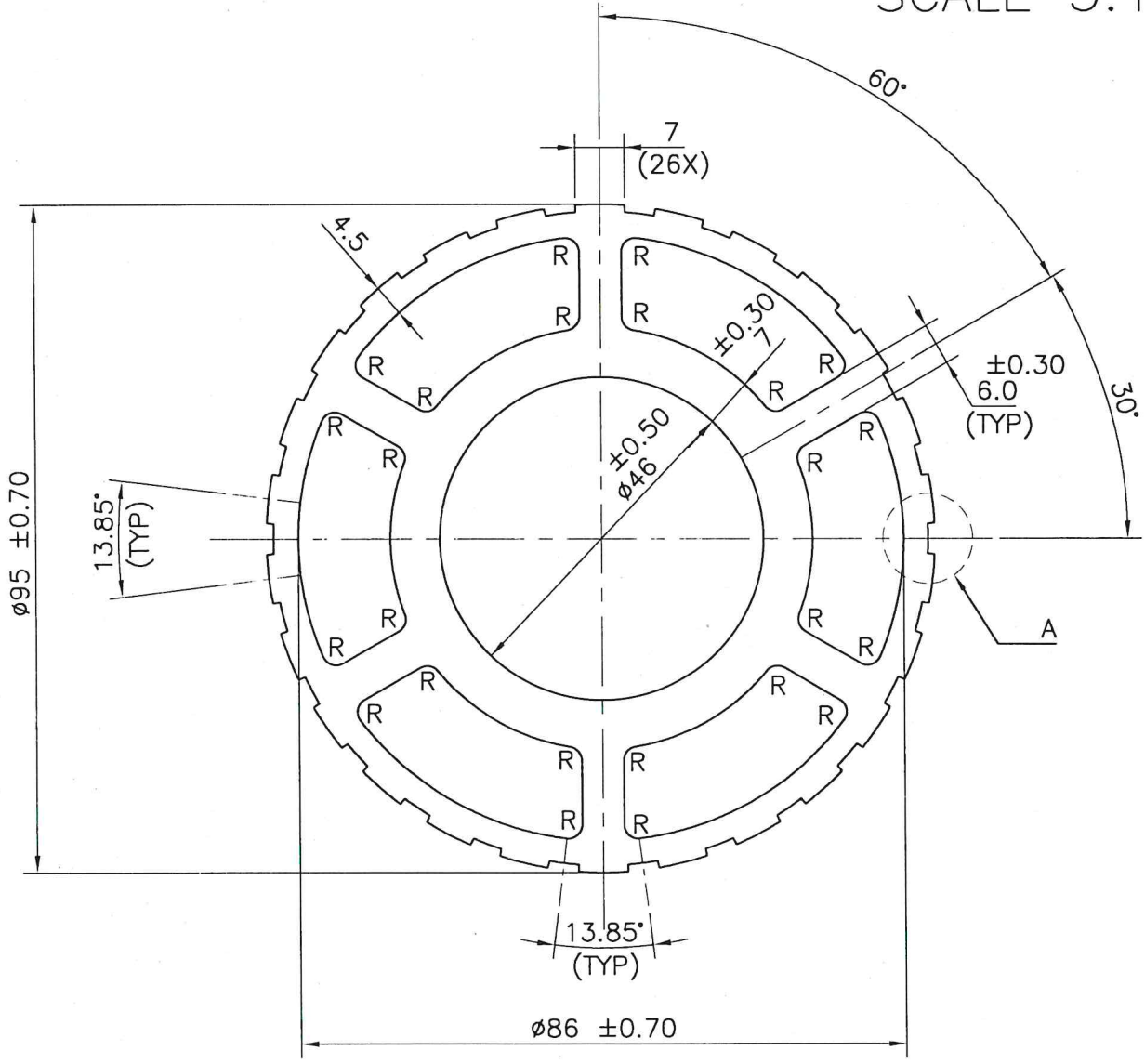

JINDAL ALUMINIUM LTD.
BHIWADI-301019 (INDIA)

	NAME	DATE
DRAWN	ASHUTOSH	30-09-2022
CHECKED	<i>fujil</i>	30.9.22
APPROVED	<i>Mani</i>	30.09.22

1. ALL DIMENSIONS ARE IN mm.
2. ROUND OFF ALL SHARP CORNERS WITH 0.40 mm.
3. TOLERANCES WILL BE AS PER BS:EN-755-9 , UNLESS OTHERWISE SPECIFIED

SCALE	1:1&3:1
AREA mm ²	2820.84
PERIMETER mm.	344.306
WEIGHT kg/m	7.616
DRAWING No.	SECTION No.
P-JAL-B-029	B-1814
-	-
-	-
-	-

PARTY'S NAME	M/S. JAL BHIWADI (ROLLER & PIN FOR RUN OUT SECTION OF BP4 PRESS)
PARTY'S DRAWING No.	AS PER DRAWING (APS-BP4-014)
ALLOY & TEMPER	6063-T6
DESCRIPTION	--